

1. Functional Description

VS positive displacement flowmeters are volume rate measuring sensors based on the meshing gear principle and are designed for use with liquids. Two precisely matched gear wheels are enclosed in a very accurately machined housing. Gear rotation is sensed by a non contacting signal pick-up system. Each tooth produces 3 impulses.

2. Technical Data

Size	Flow Range ℓ/min	GPM	K- Factor Imp./ ℓ	Imp./ Gal.
VS 10	1,5525	0.3963138.69	300	1135.63

Accuracy	±0,5 % of measured value at viscosity >20 mm ² /s (< 20 mm ² /s reduced accuracy)		
Repeatability	± 0,05% under same operating conditions		
Materials	Body	Bearings	Seals
	EN-GJS-600-3U EN 1563	Ball / Plain / Plain (copper-free), dependent on liquid	FPM (Standard) NBR, PTFE, EPDM
Max. Operating	350 bar / 5000 psi		
Medium Temperature	-40°C120°C (-40° F248° F)		
Viscosity Range	5100 000 mm ² / s		
Mounting Positions	unrestricted, on subplate with side or bottom connections		
Filtering	50µm		
Noise Level	dB(A)		
Preamplifier	short circuit proof and reverse polarity proof 10 28 V DC / 45 mA , additional current on signal output max. 20 mA		
Electrical Connection	standard 4-pin plug connection with 4-core shielded cable, Alternativ: 4-pin plug Standard: Plug with yellow cable: 5, 10, 15 oder 20 m for Ex- design: Plug with blue cable : 5, 10, 15 oder 20 m		

Block diagram

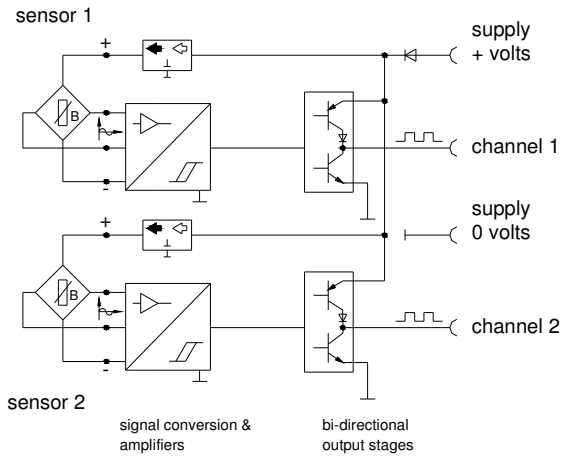

Out signals of preamplifier

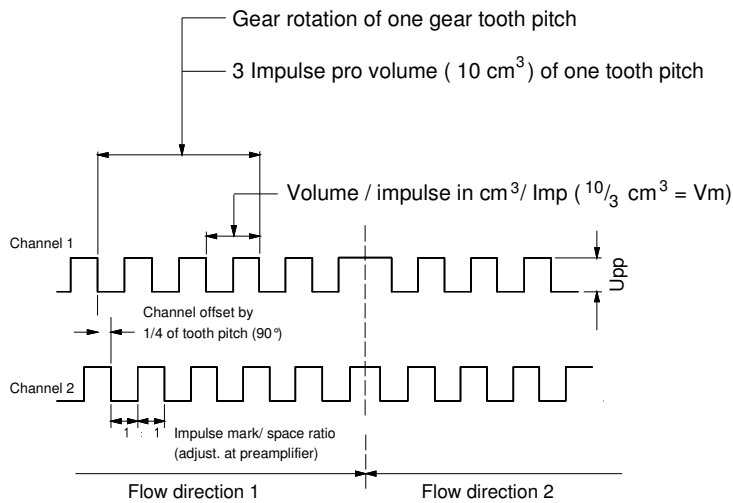

Voltage ranges

Supply voltage:
 $U_V = 10 \dots 28 \text{ V DC}$
 Impulse voltage:
 $U_{pp} = U_V - 1V$

Plug connection diagram

View A

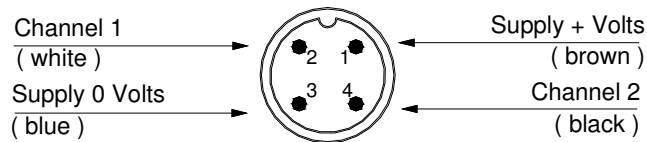

Cable connection-flowmeter to pulse processor

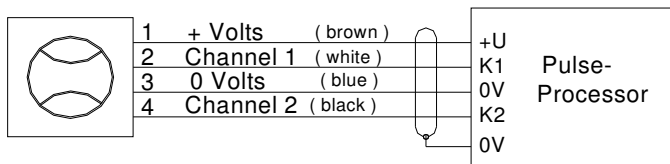

To change the flow direction sign
 (+ to - / - to +) interchange the channel
 connection
 (Channel 1 ↔ Channel 2)

Flow Response Curves

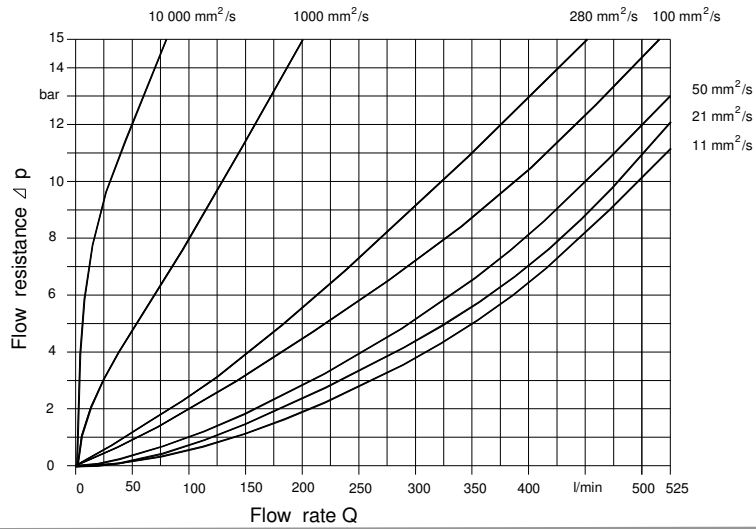

Dimensions

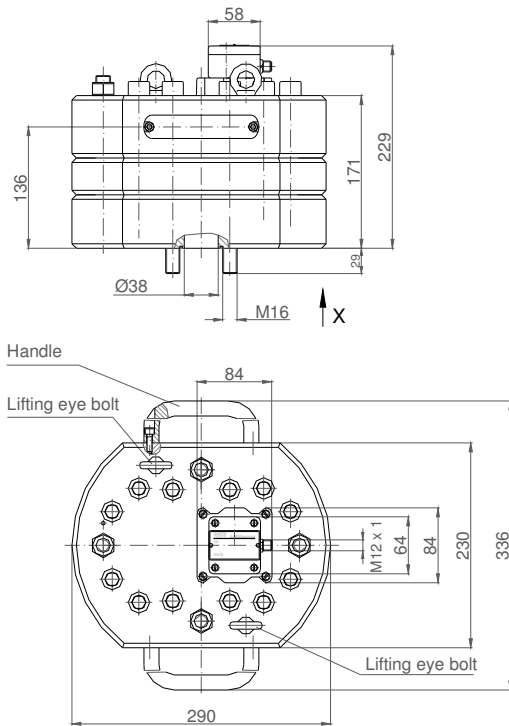

View X Connection drawing

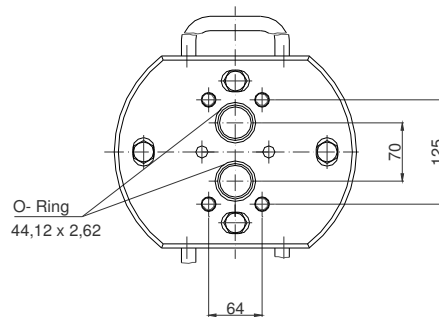

Dimensions are specified in mm

Subplate Dimensions

APG 10 SG0N / 1

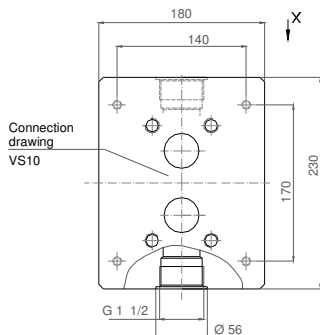

APG 10 SW0N / 1

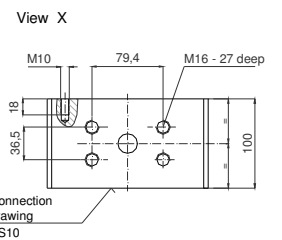
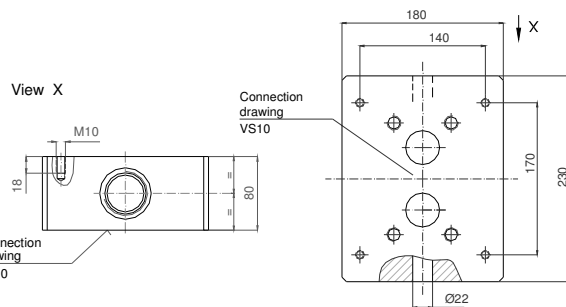

Dimensions are specified in mm

Type Codes

Flow Meters

VS 10	G	P	0	1	2	V	-	3	2	N	1	1	/	1			
Type	Material	Subplate	EN-GJS-600-3U	Type of connection	Gear surface coating	Instrument bearing	Works- determine to the application	Instrument tolerance	Works- determine to the application	Type of seals	Pick- up system	No. of pick- up	Signal output	Pre-amplifier Connection	Series		
																1	Reduced tolerance
																2	Normal tolerance (Standard)
																3	Increased tolerance
																4	Tolerance steel- plain bearing
																1	Ball- bearing
																5	Steel- plain bearing
																O	Without surface coating (Standard)
																C	Dynamat- surface coating (C - surface coating)
																T	Titan - surface coating
V	FPM (Standard)																
P	NBR																
T	PTFE																
E	EPDM																
N	Supply voltage 10...28V DC (VV GMR3) Standard																
O	Supply voltage 5 ...10V DC (VV GMR 1 Ex)																
1	1 Pick- up																
2	2 Pick- up																
3	GMR- Sensor																
1	VSE- 4 pole Standard plug connection																
0	non preamplifier integrated (Standard design)																
1	Works- determined																

Subplate

AP	G	10		S	G	0	N	/	1		
Subplate	Material	Affiliated VS flow meter size	Flow meter VS 10	Connection	Type of connection	Design	Series		Works- determine		
										G	G 1 1/2
										W	SAE 1 1/2
										X	SAE 2
										S	Side connection
										U	Bottom connection
										10	Flow meter VS 10
										G	EN-GJS-400-15U

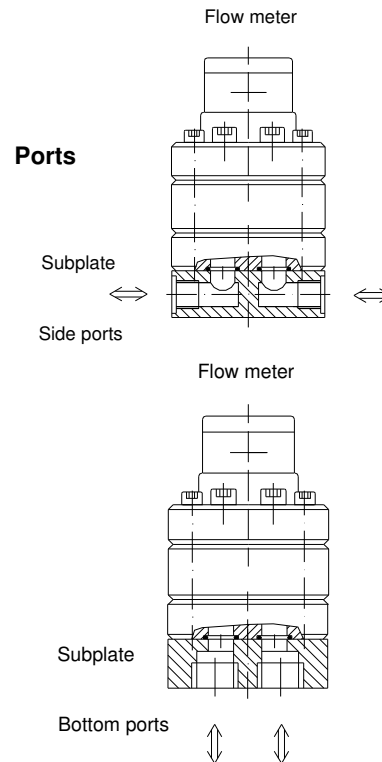

UK Flow Ltd.
 28 Aylsham Close, Hough Green,
 Widnesparc
 UK- WA8 4FF Cheshire
 Tel. +44 (0)151 424 88 65
 Fax. +44 (0)151 510 32 92
 info@uk-flow.com
 www.uk-flow.com



VSE GmbH
 Hönnestraße 47
 58809 Neuenrade
 Germany
 Tel. +49 (0)2394 / 61630
 Fax +49 (0)2394 / 61633
 info@vse-flow.com
 www.vse-flow.com