



## Instruction Manual



## TECHNICAL DATA

- Precision:  $\pm 0,5 \%$ .
- Repeatability:  $\pm 0,1\%$ .
- Rangeability: 10:1.
- Pipe Fittings: DIN 2501 Flanges.  
Others on demand.
- Materials: Body en EN1.4404 (AISI-316L)  
Propeller en EN1.4016 (AISI-430)
- Working pressure:
  - Standard: PN 16
  - On demand: up to 3000 bar
- Working temperature:
  - Standard:  $-50^{\circ}\text{C} \dots +150^{\circ}\text{C}$ .
  - On demand:  $-200^{\circ}\text{C} \dots +150^{\circ}\text{C}$ .
- Electrical connection: IP65 connector.  
On demand, With EExd terminal box mounted on the turbine.
- Response time: 10 ms.
- Pick-up signal amplitude :  $> 15 \text{ mV}$  .  
Proportional to the flow rate.
- Recommended cable: Shielded bifilar up to 30 m length. For distances up to 100 m the APTM-44 amplifier can be used. For distances up to 3000 m the CI-420 frequency to current converter can be used .

- Conforms with the Pressure Equipment Directive 97/23/CE.  0830



This equipment is considered as being a pressure accessory and **NOT** a safety accessory as defined in the 97/23/CE directive, Article 1, paragraph 2.1.3.

- Auxiliary Electronics:
  - CIP:
    - Battery powered volumetric counter.
  - MC-01:
    - Flow rate and volume indicator with batching pre-selection.
  - MT-02:
    - Volume counter with batching pre-selection.
  - DFD-2:
    - Frequency divider for control instruments.
  - CI-420:
    - Analog transmitter for control instruments.
  - APTM-44:
    - Amplifier for the pick-up signal. .

For more information consult the specific catalogues.

## K FACTOR (PULSES / LITRE)

DN	Pulses / Litre $\pm 10 \%$	$\text{cm}^3$ / pulse $\pm 10 \%$
10	2500	0.4
15	780	1,28
20	500	2
25	220	4,5
40	60	16
50	20	50
60	10	100
80	5	200
100	3	333
125	1,5	666
150	0,8	1250
200	0,3	3333

Table 1

Average values for water at 20 °C

## MAXIMUM AND MINIMUM RECOMMENDED FLOW RATES

DN	MINIMUM FLOW RATE m <sup>3</sup> /h	MAXIMUM FLOW RATE m <sup>3</sup> /h	Pressure drop (mm H <sub>2</sub> O) at maximum flow rate	MAXIMUM INTERMIT- TENT FLOW RATE m <sup>3</sup> /h
10	0,2	1	7500	1,4
15	0,3	3	7500	5
20	0,6	6,8	7500	8
25	0,9	13,5	7000	16
40	1,9	30	5600	40
50	5	50	2800	60
65	9	90	2400	115
80	15	150	3100	180
100	28	280	4500	340
125	45	450	2400	560
150	65	650	2500	820
200	110	1100	2800	1300

Table 2

## DIMENSIONS AND WEIGHTS

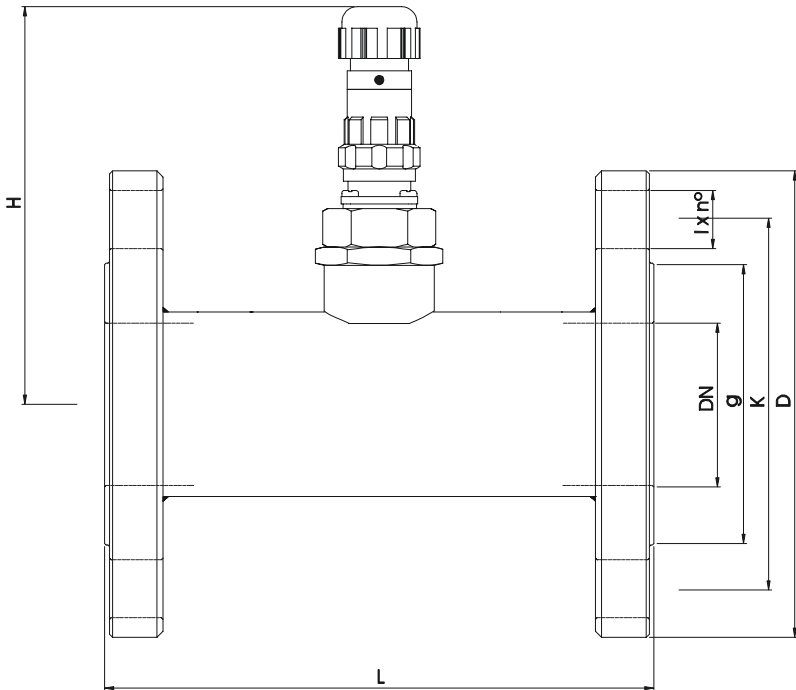

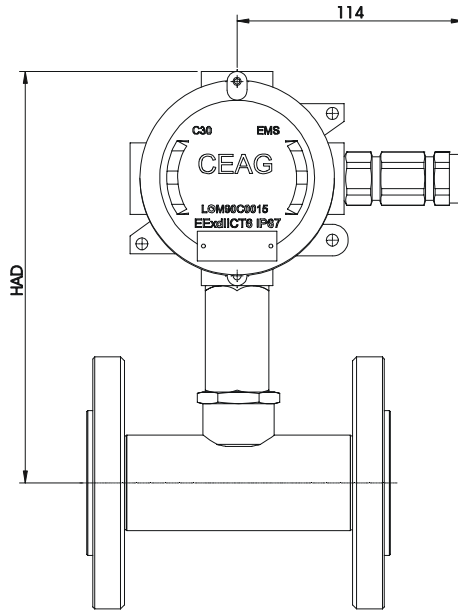

DN	D	k	g	l x No.	L	Flange PN	H <sub>(max)</sub>	HAD <sub>(max)</sub>	Weight (kg)
10	90	60	40	14 x 4	100	40	120	210	1,6
15	95	64	45	14 x 4	100	40	120	210	1,9
20	105	75	58	14 x 4	100	40	120	210	2,1
25	115	85	68	14 x 4	130	40	120	210	3,6
40	150	110	88	18 x 4	150	40	130	220	6,2
50	165	125	102	18 x 4	180	40	130	225	7
65	185	145	122	18 x 4	200	16	140	230	10
80	200	160	138	18 x 8	230	16	145	240	12
100	220	180	158	18 x 8	250	16	155	250	17
125	250	210	188	18 x 8	280	16	170	260	21
150	285	240	212	23 x 8	300	16	180	275	27
200	340	295	268	23 x 8	400	10	210	300	50

Table 3

**PARTS LIST**

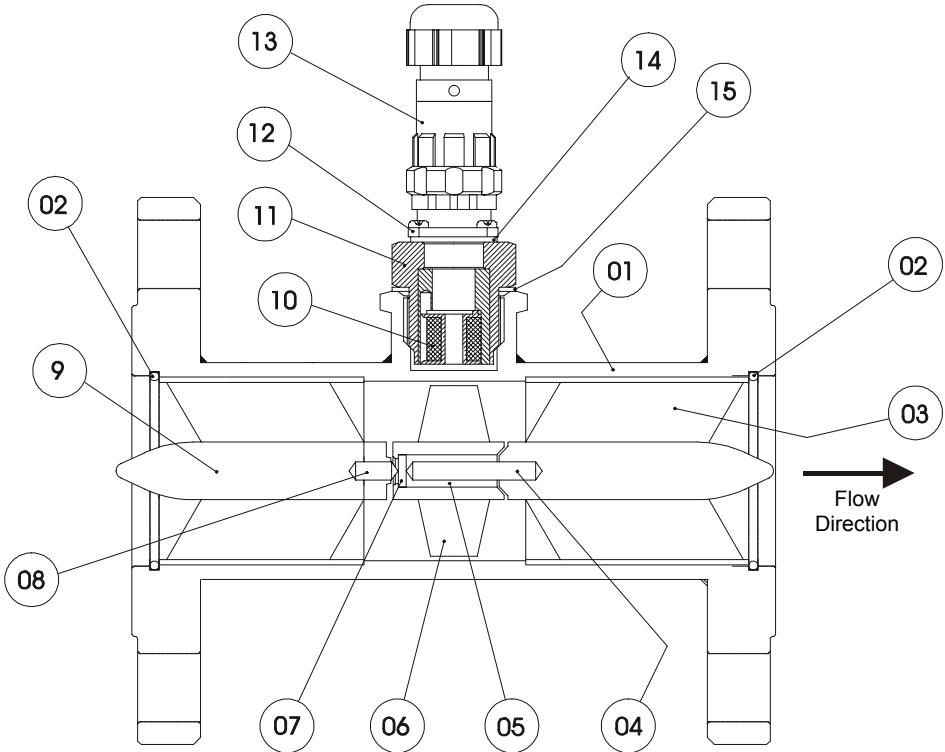

No.	Part	Material
1	Metering tube	EN 1.4404
2	Circlips	EN 1.4401
3	Outlet Deflector	EN 1.4404
4	Shaft	Tungsten
5	Bearing	Graphite
6	Propeller	EN 1.4016
7	Disc	Tungsten
8	Stop	Tungsten
9	Inlet Deflector	EN 1.4404
10	Coil	_____
11	Coil support	EN 1.4404
12	Connector base	Aluminium
13	Female Connector	Aluminium
14	Seal	NBR
15	Seal	PTFE

## WORKING PRINCIPLE

When a fluid (gas or liquid) flows through the metering tube it forces the propeller to rotate. The speed is proportional to the flow rate. Each complete turn of the propeller corresponds to a volume of fluid that flows through the flow meter.

The passing of each blade of the propeller distorts the magnetic field of an exteriorly mounted pick-up. This generates a signal of a frequency proportional to the flow rate. This signal would be the input to electronic equipment.

The TM-44 turbines are calibrated in our test rigs. This allows us to know the precise pulse/litre factor for each one.

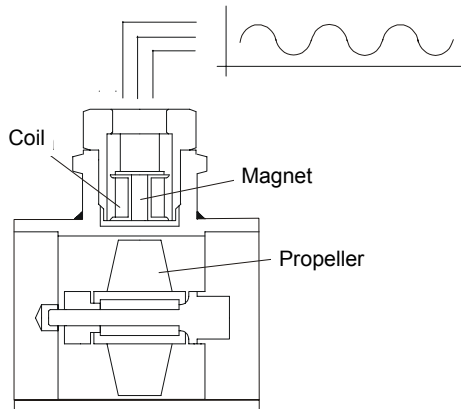

## RECEPTION

The TM-44 turbines, and any associated equipment, is supplied individually packed for protection during transport and storage.

All equipment has been tested and is ready to use once it is mounted and wired according to these instructions.

## INSTALLATION

### Mechanical part

The turbine can be mounted in any position, horizontal, vertical or inclined. Make sure that the flow direction is as marked by the arrow on the turbine body.

To obtain good readings, turbulences **MUST BE AVOIDED**. For this it is necessary to have straight sections of pipe upstream and downstream of the turbine. The straight pipe sections must be of the same internal diameter as the turbine and the minimum lengths must be equivalent to 10 DN for the upstream section and 7 DN for the downstream section. These sections must be free of deviations or obstructions (valves etc.).

These distances can be reduced by installing a flow straightener upstream of the turbine at a distance equivalent to 5 DN.

The pipe must be completely full of the product to be measured and in the case of liquid, it must be free of air. If there is any possibility of an air intake in the installation, an air extractor should be installed before the counter.

**A FILTER MUST BE INSTALLED** before the turbine to guarantee correct working and avoid expensive damage. The filter should have a mesh for a maximum of 200 microns to avoid larger particles that may block the turbine propeller .

## Electrical part

This consists of a pick-up that generates a periodic electrical signal when each blade of the propeller passes in front of it.

IT IS IMPORTANT THAT THE INSTALLATION OF THE CABLE BETWEEN THE TURBINE AND THE ASSOCIATED EQUIPMENT SHOULD BE KEPT AWAY FROM MAINS AND POWER CABLES.

In any event they should be separated a minimum of 5 cm from these cables.

For the connection to the pick-up the turbine has a male receptacle connector (12) and a female plug (13).

Unscrewing the smaller nut access is gained to the three terminals where the cables are to be soldered. If this piece must be removed for soldering elsewhere, unscrew the larger nut and withdraw the terminal block.

The terminals are numbered 1 to 3 and should be connected as follows:

- N° 1: Earth
- N° 2: Coil
- N° 3: Coil

Before making the solder joints, loosen the cable gland nut and pass the cable through it, and also through the larger nut.

The electrical connection should always use tidy soldered joints avoiding possible short circuits between terminals.

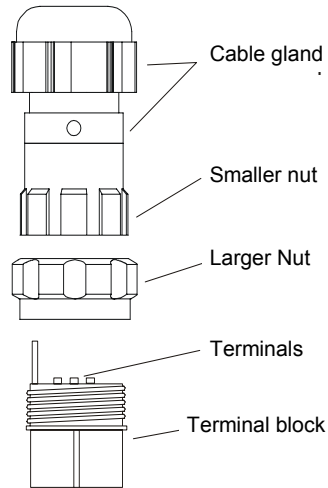

Once the connections are made, mount the cable gland on the terminal block and tighten the cable gland nut to avoid entry of liquid or humidity.

Once the female connector has been assembled, the coupling to the receptacle has only one position defined by the tongue and groove.

Check that the seal inside the receptacle is correctly situated and plug in the female connector, tightening the larger nut until the end of the thread is noted.

### Possible operation problems (PROBLEM / Possible cause / Solution)

– COUNTER STOPS COUNTING OR GIVES A LOWER READING THAN THE REAL VOLUME.

Blockage or friction of the turbine propeller by particles.

*Install a filter as recommended (maximum 200 microns)*

– COUNTER GIVES A HIGHER READING THAN THE REAL VOLUME.

Presence of air pockets. Excessive emptying of storage tanks.

*Control the minimum tank level. Provide an air extractor upstream of the turbine if air intakes can be expected.*

#### Cavitations

*Avoid installing the turbine in low pressure sections, for example in suction sections of a pump or in down-flowing discharge pipes with free outlets. In these cases air pockets can get trapped in the turbine and produce unbalance of the propeller which could damage the turbine.*

**Note:** *To avoid cavitations the pressure at the outlet of the turbine should be greater than twice the pressure loss of the turbine (see table N° 2) plus 1.25 times the vapour pressure of the liquid*

*or of its most volatile component.*

#### – FLUCTUATIONS IN VOLUME (BATCHING PROCESSES)

It can happen that after each batching cycle, different quantities of liquid will be trapped in the length of pipe after the valve.

*The pipe after the valve should always be completely full or empty after each batch. This can be achieved by:*

- *(Empty pipe) The valve must be installed after the turbine and the outlet of the valve will feed into a funnel at the beginning of the discharge pipe. The air inlet at the funnel and the slope of the discharge pipe will guarantee that the pipe will empty after each batch.*
- *(Full pipe) This possibility is valid when batching only one product. This can be achieved in two ways:*

*The discharge pipe is situated above the level of the turbine.  
Installing the valve at the outlet of the discharge pipe.*

## **MAINTENANCE**

The simple construction of the TM-44 turbine results in a long life in normal working conditions.

The life of the parts depends mainly on the abrasive characteristics of the product to be measured and the maximum flow rate.

The combination of these two factors make it difficult to estimate the life of the components in good working conditions.

**NOTE.** If the maximum flow rates given for each DN in Table 2 are exceeded the life is considerably reduced.

The only parts that may need periodical maintenance are the propeller shaft and bearing. The rest of the pieces will only need maintenance when there is chemical attack or abrasion by the fluid being measured.

It has been confirmed that the life of these parts under normal working conditions is greater than 20.000 hours.

## **Dismounting**

The numbering of the different elements corresponds to the table and drawing in the "Parts List" section on Page 5.

In the interior of the metering tube (1) are located the deflectors (3) & (9) and the propeller (6). The inlet deflector (9) has a stop (8) inserted and the outlet deflector (3) has a shaft (4).

The deflectors (3) & (9) are dismounted by withdrawing the circlips (2) which hold them in. They are mounted at about 5 mm from the ends of the metering tube (1) and are easily removed with a screwdriver.

First remove the circlip (2) of the outlet deflector (3). Place the turbine in a horizontal position and withdraw the deflector. The propeller assembly will come out together with the deflector.

Remove the circlip (2) at the other end and withdraw the inlet deflector (9).

## **Cleaning**

The propeller assembly contains the bearing (5) and tungsten disk (7). These must not be dismounted.

To clean the inside of the bearing (5) use a cloth or soft paper wrapped around a fine shaft; do not use abrasive elements. Cleaning liquids can be used to help remove dirt or grease.

To clean the propeller shaft (4) clean with a cloth soaked in alcohol, soapy water or solvent. The propeller should rotate freely on the shaft but should not be loose. It should not have a play of more than 1 part in 50 of the shaft diameter.

The rest of the pieces can be cleaned with the same products.

## Mounting

Before starting to mount the turbine make sure that all the pieces are completely dry, with this we can prevent the propeller shaft from seizing.

The turbine should be mounted as follows:

Slide the inlet deflector (9) in its place (use the flow direction arrow to determine the correct end) and fix it with a circlip (2).

Fit the propeller assembly on the shaft (4) of the outlet deflector (3). With the metering tube (1) in a horizontal plane introduce the outlet deflector assembly and fix it with a circlip (2).

Check that the assembly is without play and that the two circlips are correctly seated. There should only be about 0,5 mm axial play of the propeller assembly on its shaft.

The turbine is ready for installation and operation.

## Changing the pick-up

The hermetic seal between the coil support (11) and the metering tube (1) is obtained by the PTFE washer (15).

The female plug (13), as indicated in the Installation section, can be removed from the base (12) by unscrewing the larger nut. The connector base is fixed to the coil support (11).

Unscrew the coil support (11) from the turbine metering tube (1). In the inside there is a coil-magnet assembly which is protected by a PTFE cylinder. The coil is soldered to the connector base terminals. If this is dismantled the coil wires could break.

It is important to check that the separation, between the end of the coil and the bottom of its seat in the turbine metering tubes, is not greater than 1 mm. To do this take the measurements shown in the drawing and check  $L2 - L1 < 1 \text{ mm}$ . Note that  $L1$  is measured with the PTFE washer (15) in place. In the event that the distance is greater, a thinner washer must be used.

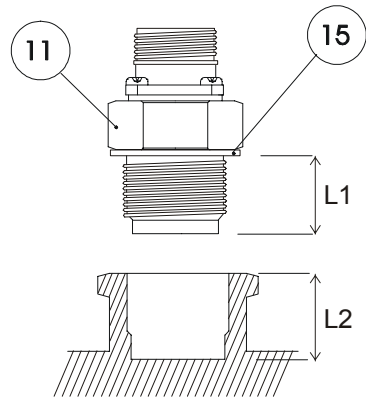

## DETECTING PROBLEMS

Symptom: The associated electronic equipment will not count or will not give a flow rate reading.

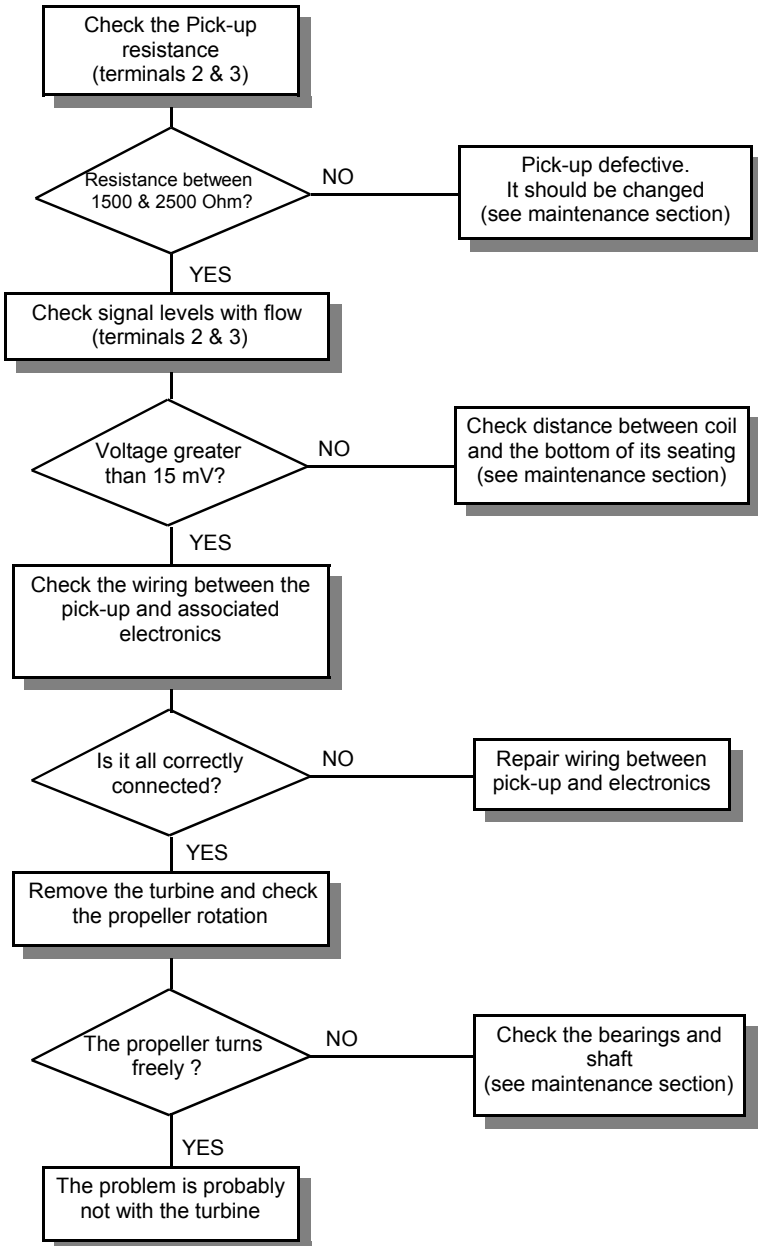

# APPLICATIONS

Filling tanks

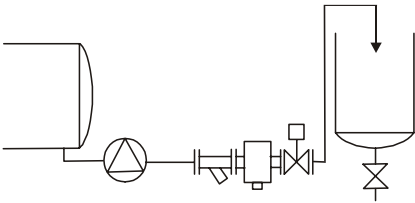

Counter and electro valve in the working area

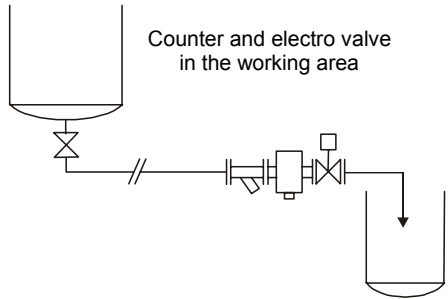

Measuring condensed steam and fuel consumption

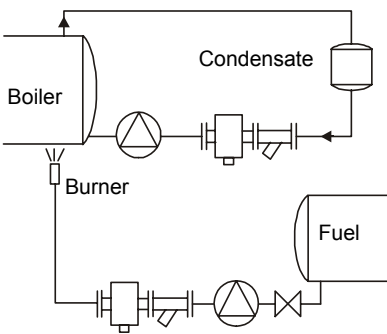

Counter in storage area and electro valve in working area

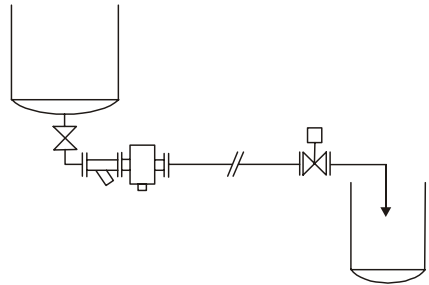

Full pipe

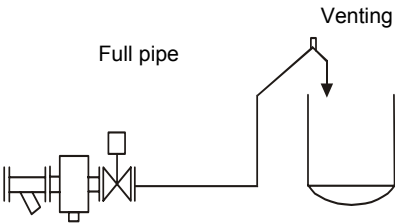

Venting

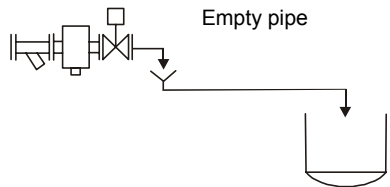

## **WARRANTY**

Tecfluid S.A. GUARANTEES ALL ITS PRODUCTS FOR A PERIOD OF 24 MONTHS, after consignment, against all defects in materials and workmanship.

This warranty does not cover failures which can be imputed to misuse, use in an application different to that specified in the order, the result of service or modification by un-authorized persons, bad handling or accident.

This warranty is limited to cover the repair or replacement defective parts which have not been damaged by misuse.

This warranty is limited to the repair of the equipment and all further and eventually following damages are not covered by this warranty.

Any consignment of equipment to our factory or distributor must be previously authorised. The consignment should be done with the equipment well packed, clean of any liquids, grease or hazardous materials. Tecfluid S.A. will not accept any responsibility for damage done during transport.

Together with the equipment, a note should be enclosed indicating the failure observed, the name, address and telephone number of the sender.

---

**TECFLUID, S.A.**  
Narcís Monturiol, 33  
E-08960 Sant Just Desvern  
Tel. + 34 93 3724511 - Fax + 34 93 4734449  
E-mail: [tecfluid@tecfluid.com](mailto:tecfluid@tecfluid.com)  
Internet: [www.tecfluid.com](http://www.tecfluid.com)

---

The technical data in this pamphlet is subject to modification without notification, if the technical innovations in the product or manufacturing processes so require.