

CHLORTROL Series 17T2000 Amperometric Titrator



CAPITAL CONTROLS



- ◆ **Enhanced end point detection:** Solid state circuitry provides a characterized log/linear signal to the meter giving maximum meter deflection as end point is approached.
- ◆ **Portable:** Powered by a rechargeable battery. Contains a built-in battery charger and 3 prong line cord.
- ◆ **Self-Contained Titrant Reservoir:** From which the internal pipet can be filled by gravity. Has ample 500ml capacity.
- ◆ **Two metal Electrode:** Requires no salts and may be easily removed and cleaned without tools.
- ◆ **“Total-Off-Free” Switch:** Mounted on front of unit for selection of proper electrode potential. One hand operation with no potentiometer to balance.
- ◆ **Ease of Operation:** From start to completion of titration procedure.

The Series 17T2000 Amperometric Titrator is an analytical instrument for the electrical determination of the end point of a titration for free, combined, or total chlorine residual. It can also be used to determine bromine, iodine, ozone, permanganate, and chlorine dioxide residuals.

In addition, the titrator can be used to monitor the chlorite and chlorate output concentrations of chlorine dioxide generators and determine sulfur dioxide concentrations of process water.

The instrument is suitable for use in water and wastewater plants, swimming pools, research laboratories, and industrial plants when fast, accurate titrations are required. It can be easily operated, without special instruction, by a laboratory technician and is suitable for tests in “Standard Methods” and ASTM Method D-1253.

Completely portable, the titrator operates either from a self-contained, completely sealed lead-acid battery or from standard 120 or 220/240 Vac power. The battery can be recharged merely by leaving the unit plugged into an “AC” socket overnight.

ENGINEERING SPECIFICATIONS

Sensitivity: 5 parts per billion (0.005 mg/L) of residual chlorine

Electrical Requirements: Battery operated. 120 or 220/240 Vac 50 or 60 Hz 5 watts max. power source required for integral battery charger. Titrator may also be operated with 120 or 220/240 Vac 50 or 60 Hz source without change of parts.

Low Battery Indicator: A front mounted LED warns of a low battery condition by flashing at an increasing rate as the battery drops below the 25% charge level. It serves as a pilot light when charge is above 25%.

Materials of Construction:

Base: Molded FRP pedestal

Housing: Molded ABS plastic

Front Panel: Polycarbonate

Weight: 11 pounds (5 kg)

OPERATION

Remove the cover and, depending on expected residual range, select the normal or high sensitivity range switch position and either the 5mL or 1mL pipet. The pipets are easily interchangeable and the one not being used is stored within the housing to prevent loss or breakage. Replace the cover and place the sample beaker containing a 200mL sample on the titrator. This immerses the electrodes in the sample and also the titrant dispensing tubing to eliminate hanging drop error. The pipet is filled by opening the refill valve on the titrator to allow titrant to flow from the internal reservoir into the pipet. When the pipet is full, the valve is then closed.

The titrator is switched on by pushing the three-position switch on the front of the instrument up or down, depending on the type of residual to be measured. With the switch in the down position, a dc potential of the proper value for the titration of total residual is impressed on the electrodes. With the switch in the up position, a dc potential of the proper value for the titration of free residual is impressed on the electrodes. Switching also energizes a small motor driven propeller

Free Residual:

The switch is pushed up and pH7 buffer is added. The phenylarsene oxide titrant is added to the agitated sample from the pipet by opening the titrate valve. Each time the pipet is emptied, either one or five mL of titrant has been added. Each mL equals one mg/L of free residual chlorine in the 200mL sample. The pipet is graduated in mL, each graduation equals 0.01 mg/L on the one mL pipet and 0.1 mg/L on the five mL pipet.

The titrant reduces the chlorine in the sample thereby decreasing the flow of current between the electrodes, which is proportional to the amount of chlorine remaining in the sample. Although the current decrease is linear with decreasing residual, the titrator's solid state circuitry provides a characterized log/linear signal to the meter, giving maximum meter deflection as the end point is approached. The change in current flow is indicated by the milliammeter on the face of the instrument.

When sufficient titrant has been added to reduce all of the free chlorine in the sample, the "end point" has been reached. At this point no further current reduction is possible, nor is there any further movement of the milliammeter pointer. A meter deflection curve for a typical low residual titration is shown below.

Total Residual:

The switch is pushed down and pH4 buffer and potassium iodide are added to the sample. The potassium iodide liberates iodide in proportion to the amount of total residual chlorine present. The normal titration procedure is then followed with the iodine being reduced by the phenylarsene oxide in the same manner as free chlorine. Each mL of phenylarsene oxide added equals one mg/L of total residual chlorine. The total residual for the sample is the sum of the free and combined residuals.

Combined Residual (Chloramines):

By the use of the above procedures, the free residual and the total residual for a given sample can be determined. The combined residual is equal to the total residual minus the free residual.

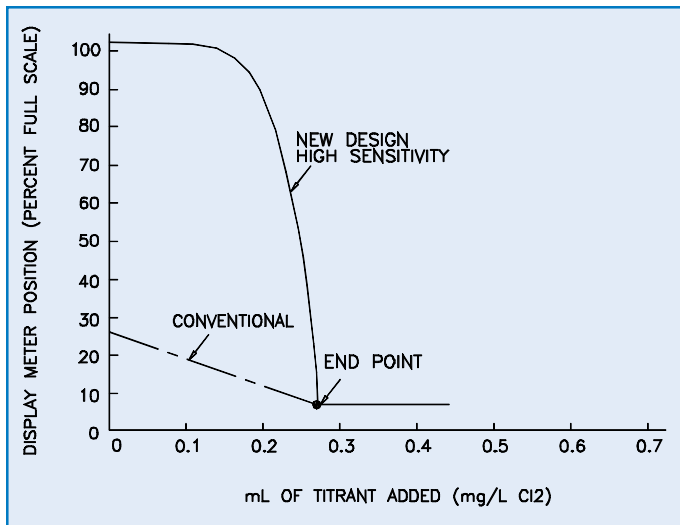

Titration Curve

CHLORINE DIOXIDE TITRATIONS

An optional kit is available consisting of a special electrode, a 10mL buret with stopcock, buret tip, and instructions which permit the titrator to be used to determine chlorine dioxide generator yields or efficiency. The kit also permits the titrator to be used to determine chlorine dioxide residuals in plant process water or wastewater. While chemicals are not supplied with the kit, they are listed in the instructions and are commercially available.

ACCESSORIES

Standard: Graduated sample beaker, 2 pipets (1mL and 5mL), dropper bottles, all chemicals required for standard chlorine titrations and cotton swabs for electrode cleaning.

Optional: Carrying case for titrator and standard accessories. The case is molded ABS plastic with a heavy-duty handle and internal foam padding with cutouts for the titrator and bottles of chemicals. Approximate size is 24 in (609 mm)H x 15 in (389 mm)W x 9 in. (228 mm)D.

Back titration kit is available to be used to determine total residual chlorine when the sample contains organic compounds that would interfere with the results of an ordinary titration.

Additional chemicals.

EQUIPMENT DESCRIPTION

The amperometric titrator shall be a completely portable device operating from a self-contained, completely sealed, lead-acid battery and be capable of determining the end point in titrations for chlorine residual with a sensitivity of 0.005 mg/L. Within the molded ABS housing and FRP base are the built in battery charger and 3 prong line cord. Power required for the battery charger or lab operation is (120) (220/240) Vac 50 or 60 Hz. The front panel shall contain an LED, which functions as both a pilot light and, when flashing, as a reminder that the battery needs recharging.

The electrode cell shall consist of 2 metal electrodes in a single plug in holder, on which, a dc potential shall be impressed. The unit shall be equipped with a switch to select the proper impressed electrode potential for either free or total residual so that there will be no potentiometers to balance or salt bridges to maintain.

The unit shall come complete with 1mL and 5mL pipet with the unused one being stored within the unit to prevent loss or breakage. An internal switch shall be used to select high or normal sensitivity depending on residual range to be titrated. Solid state circuitry shall be utilized to provide a characterized log/linear signal to the vertical display meter giving maximum meter deflection as the end point is approached. The unit shall provide maximum one hand operational convenience that does not require re-ranging as the titration process progresses. A built in multi-turn needle valve shall be mounted on the titrator for the accurate addition of titrant. The titrant shall be dispensed from an internal, collapsible plastic bag with a 500mL capacity.

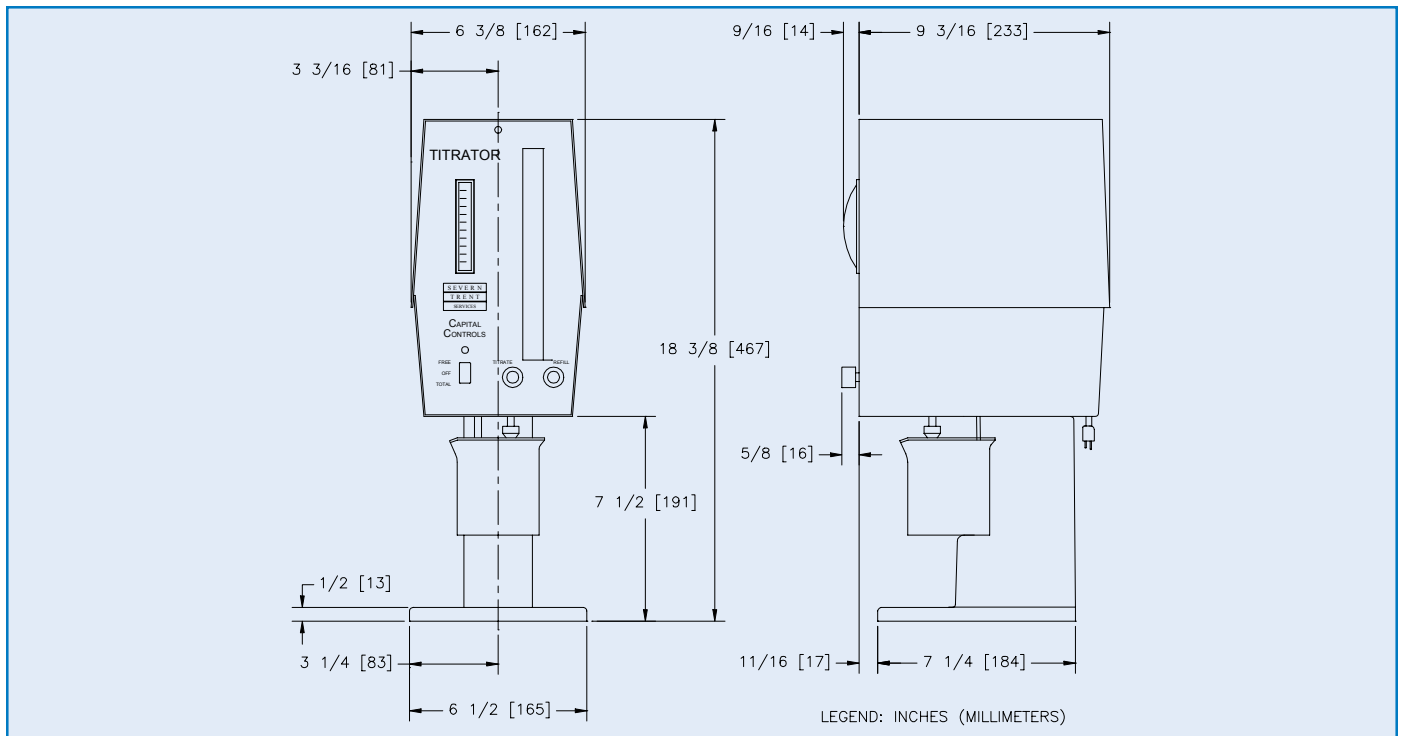

MODEL NUMBER DESIGNATION

	<u>17T2</u>	<u>A</u>	
AMPEROMETRIC TITRATOR	17T2		
POWER REQUIREMENT			
120 Vac, 50/60 Hz 01		01	
220/240 Vac, 50/60 Hz		02	
CHEMICALS REQUIREMENT			
Not Required, Solution Bag Only		1	
Required, Solution Bag w/Titrant		2	
DESIGN LEVEL			
Letter assigned by factory		A	
TITRATOR PROBES			
Chlorine Probe			X
Chlorine Dioxide Kit and Chlorine Probe			B
Chlorine Dioxide Kit Only			C
ACCESSORIES			
None Required			X
Carrying Case			B
Back Titration Kit			C
Case and Back Titration Kit			D

The titrator shall be a Capital Controls Series 17T2000 and be supplied with standard accessories including the following chemicals:

- 500mL phenylarsene oxide solution
- 120mL potassium iodide solution
- 120mL pH 4 buffer solution
- 120mL pH 7 buffer solution
- *A carrying case for the titrator and standard accessories shall be supplied with the unit.
- *A back titration kit shall be supplied to permit the use of the standard back titration method for total residual.
- *Chlorine Dioxide Titration Kit
- *(Optional)

Note: not included are the chemicals and ultra-pure nitrogen required for chlorine dioxide analysis.

ORDERING INFORMATION

Please Specify:

- Complete Model Number Or
- Series 17T2000 Amperometric Titrator with standard accessories
- Optional accessories desired
- Power Requirement

Design improvements may be made without notice.

Represented by:



CAPITAL CONTROLS

Severn Trent Water Purification, Inc.
 3000 Advance Lane Colmar, PA 18915
 Tel: 215-997-4000 • Fax: 215-997-4062
 Web: www.severntrentservices.com
 E-mail: marketing@severntrentservices.com

UNITED KINGDOM • UNITED STATES • HONG KONG
 INDIA • ITALY • MALAYSIA