

# UNIVERSAL® Flow Meters

## A Small Vane-Style For Corrosive Fluids



CSA Certified NRTL/C



CE Marked (as noted)

**NIST** Traceable Calibration  
Certificate Available



*SX shown with "A"  
style control box.*

### DESCRIPTION

These flowmeters have plastic bodies, a wide variety of metal internals, and fittings. They are ideally suited to monitor flows of such fluids as corrosive liquids, seawater, deionized water, acids, caustics, and plating solutions.

These variable-area flow meters have a spring-loaded swinging vane. Mounting is in-line and in any position. Straight pipe runs before or after the meter are not required. The all-mechanical sensing system directly drives the pointer and remote signaling devices. They handle shocks or flow surges beyond their rated capacities.

### CALIBRATION

All flow meters are individually calibrated for fluids with the viscosity you specify (up to 3000 SSU/650 centipoise). We also compensate for your fluid's specific gravity. For NIST Traceability please consult factory.

### CONSTRUCTION MATERIALS

Housings are corrosion-resistant PVC or Polysulfone. Wetted internal parts are 316 stainless steel, titanium, tantalum, monel, or Hastelloy C. Seals are Buna N, EPR, Viton, Kalrez, or Kalrez combined with one of the others listed above.

### LINE CONNECTION

Ports can be threaded or flanged. Threaded adapters (plastic or 316SS) can be NPTF/NPTM from 1/4 to 3/4" or 1" NPTM. Adapter fittings are threaded into the 7/8 to 1/4" SAE straight-thread O-ring-sealed ports in the housing. Metric threads such as BSPP, BSPT or JIS are also available. PVC flanged connections are also available.

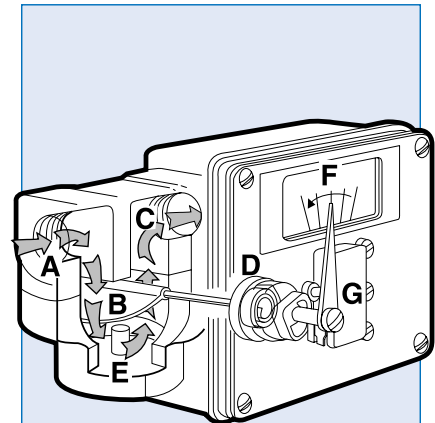

Fluid enters at **A**, passes around the semi-circular vane **B**, exits at outlet **C**. The vane resists the flow because of the spring **D**. The further the vane is pushed the larger the passageway **E** becomes. This minimizes the increase in pressure drop. The vane shaft turns to operate the pointer **F** and remote signal devices such as the switch **G**.

**HOW TO ORDER** Select appropriate symbols and build a model code number, as in example shown:

**EXAMPLE: SX - P I B 6 GM - 4FS - 32V1.0 - A 3 W L - ST - C - 2D**

**SERIES**  
Small vane style  
corrosion resistant = **SX**

**HOUSING MATERIAL**  
PVC = **V**  
Polysulfone = **P**

**INTERNAL MOVING PARTS**  
316 Stainless Steel = **I**  
Titanium = **T**  
Monel = **L**  
Tantalum = **R**  
Hastelloy C = **C**

**SEAL MATERIAL**  
Buna N = **B**  
EPR = **E**  
Viton = **F**  
Kalrez = **J**  
Kalrez (dynamic)/Buna N (static) = **A**  
Kalrez (dynamic)/EPR (static) = **H**  
Kalrez (dynamic)/Viton (static) = **K**

**FLUID CHARACTERISTICS**  
Viscosity number followed by a 'V' (for SSU) or a 'C' (for centipoise), or 'CS' (for centistokes), plus the fluid specific gravity. (**32V1.0** would mean water.) For dual viscosity give two numbers separated by a slash (example: 320/500V1.0).

**PORT ADAPTER**

	NPT	Max Flow	Plastic*	Plastic*	316 S.S.
Inches	MM	(gpm)	Male	Female	Female
1/4	6.350	8	<b>2MP</b>	<b>2FP</b>	-
1/2	12.70	10	<b>4MP</b>	<b>4FP</b>	<b>4FS</b>
3/4	19.05	10	<b>6MP</b>	<b>6FP</b>	<b>6FS</b>
1	25.40	10	<b>8MP</b>	-	-

\*Material will be same as housing;  
Adapter O-ring will be same as static seal material.  
For PVC flanged connections, consult factory.

**SCALE CALIBRATIONS**  
Calibrated in gallons per hour = **GH**  
Calibrated in gallons per minute = **GM**  
Calibrated in liters per minute = **LM**  
Calibrated in cubic meters per hour = **CMH**  
Dual scales (GPM and LPM) = **GLM**  
Dual viscosity on GPM scale = **DGM**  
Dual viscosity on LPM scale = **DLM**  
Note: For specific calibrated increments and special scales, consult factory

**MAX FLOW RATING LIQUIDS**

These may be expressed in various engineering units as shown. Here we are selecting the maximum flow that the meter will see.  
The minimum reading is about 1/5th of the maximum. There are generally 5 to 7 major increments displayed on the analog scales (traditional mechanical pointer and inscribed scale) with that number roughly doubled for the high resolution "R" box which allows more accurate reading. Ultimate resolution is provided by the LCD digital display, standard with some transmitter selections. The following are the most commonly selected options for maximum flow rates for each engineering unit. More are available if you consult with the factory.

	Viscosity minimum (SSU)			
	500	250	100	None
GPH:	<b>30</b>	<b>60</b>	<b>90, 120</b>	<b>180, 240, 300, 200, 300, 400, 500, 600, 700, 800, 900, 1000, 1200</b>
GPM:	<b>.5</b>	<b>1</b>	<b>1.5, 2</b>	<b>3, 4, 5, 6, 7, 8, 9, 10, 15 &amp; 20</b>
LPM:	<b>2</b>	<b>4</b>	<b>6, 8</b>	<b>10, 15, 20, 25, 30, 35, 40, 45, 50, 60, 75</b>
LPH:	<b>100</b>	<b>200</b>	<b>350, 500</b>	<b>600, 700, 800, 900, 1000, 1500, 2000, 2500, 3000, 3500, 4000</b>
CMH:	<b>.1</b>	<b>.25</b>	<b>.35, .5</b>	<b>.75, 1, 1.25, 1.5, 2, 2.5, 3, 3.5, 4, 4.5</b>

Consult factory for compatibility of construction materials with the fluid involved.

## SWITCH SETTING

**No symbol** = Lowest possible  
 Or, give setting(s) in GPM or LPM. Also a symbol to indicate that accuracy is desired during increasing flow (**U**) or decreasing flow (**D**). (**2D**) would mean that switch should actuate when flow rate decreases to 2 GPM.)  
 Settings are field adjustable.

## FLOW DIRECTION

R = Left to right  
**L** = Right to left  
 U = Up  
 D = Down

## SERVICE

N = Oil and dust tight (Type 12)  
**W** = Weatherproof (Type 4)  
 X = Weatherproof, corrosion proof (Type 4X)

## SPECIAL OPTIONS

### Standard

**ST** = Stainless steel ID tag for customer supplied information  
**PC** = Pin connector (See explanation for special options.)  
**FL** = Fault light (See explanation for special options.)  
**C** = CSA enclosure / PVC window  
**TG** = Tempered glass window  
**Z67SH** = 316 stainless steel bolts on SH-I option. Pressure rating 1500 PSI Max.  
**Z86** = Clearance vane for ≥ 5 GPM

## STANDARD CONTROL BOX & READOUT (switches)

### A Box

#### Simple indication with or without switches

AØ = Scale & pointer only  
**A1** = One SPDT (3wire) , CE  
 A1B = One high vibration SPDT (3 wire), CE  
 A2 = Two SPDT (3 wire), CE  
 A2B = Two SPDT (3wire) , CE  
 A3 = One SPDT (4 wire)  
 A4 = Two SPDT (4 wire)  
 A61 = One SPDT (3 wire) high temperature  
 A62 = Two SPDT (3 wire) high temperature  
 A71 = One SPDT (3wire) gold contact  
 A72 = Two SPDT (3wire) gold contact  
 A53 = One SPDT (3 wire) hermetically sealed  
 A54 = Two SPDT (3 wire) hermetically sealed  
 A11 = Pnuematic

### X Box

#### Hazardous location indication and switches

X7 = One SPDT hazardous location  
 X7C = One SPDT, CE  
 X17 = One DPDT hazardous location  
 X17C = One DPDT, CE  
 X3Ø = One SPST hazardous location proximity  
 X31 = Two SPST hazardous location proximity

### G Box

#### Transmitter with digital display and 2 open collectors (standard), or remote display (optional)

GTLØ = internal 4-20 mA transmitter with two open collector alarms  
 GTLZØ = intrinsically safe 4-20 mA transmitter (no alarms)  
 GPØ = G Box with remote transmitter. This requires a remote display and transmitter to be ordered as a separate line item. Model UT-PM-DTLCD.

Note: G Box requires "W" service selection (weatherproof). G Box has a terminal strip but can be used with pin connectors ordered as Special Options as described above. Select PC5M for GTL and PC3M for GTLZ or GP.

## SPECIAL OFFERINGS

### R Box

#### High resolution pointer and scale for more accurate reading, optional switches

RØ = Scale & pointer only  
 R1 = One SPDT (3wire) , CE  
 R2 = Two SPDT (3 wire), CE  
 R3 = One SPDT (4 wire)  
 R4 = Two SPDT (4 wire)  
 R53 = One SPDT (3 wire) hermetically sealed  
 R54 = Two SPDT (3 wire) hermetically sealed  
 R61 = One SPDT (3 wire) high temperature  
 R62 = Two SPDT (3 wire) high temperature  
 R71 = One SPDT (3wire) gold contact  
 R72 = Two SPDT (3wire) gold contact

### RT Box

#### High resolution pointer and scale for more accurate reading, 4-20 mA Transmitter, optional high amp mechanical switch

RTØ = Scale & pointer only  
 RT1 = One SPDT (3wire) , CE  
 RT3 = One SPDT (4 wire)  
 RT53 = One SPDT (3 wire) hermetically sealed  
 RT61 = One SPDT (3 wire) high temperature  
 RT71 = One SPDT (3wire) gold contact

### TT Box

#### 4-20 mA Transmitter with pointer & scale, optional high amp mechanical switch, separate junction boxes for switch & transmitter

TTØ = Scale & pointer only  
 TT1 = One SPDT (3wire) , CE  
 TT3 = One SPDT (4 wire)  
 TT53 = One SPDT (3 wire) hermetically sealed  
 TT61 = One SPDT (3 wire) high temperature  
 TT71 = One SPDT (3wire) gold contact

### TTL Box

#### 4-20 mA Transmitter with digital display, optional high amp mechanical switch, separate junction boxes for switch & transmitter

TTLØ = Scale & pointer only  
 TTL1 = One SPDT (3wire) , CE  
 TTL3 = One SPDT (4 wire)  
 TTL53 = One SPDT (3 wire) hermetically sealed  
 TTL61 = One SPDT (3 wire) high temperature  
 TTL71 = One SPDT (3wire) gold contact

### M Box

#### Metal box for minimal indication of flow, one alarm switch and a pin connector

M1 = One SPDT (3wire) , CE  
 M1B = One high vibration SPDT (3 wire), CE  
 M3 = One SPDT (4 wire)  
 M61 = One SPDT (3 wire) high temperature

Note: Micro pin connectors must be selected. See special options section.

## ENGINEERING DATA

### Maximum fluid temperature:

PVC housing: 100°F (38°C)  
 Polysulfone housing: 200°F (95°C)

### Maximum ambient temperature:

130°F (55°C) (UL listed to 105°F (40°C);  
 for hazardous locations -13 to +104°F.)

### Maximum operating pressures: (3:1 safety factor)

PVC housing: 100 PSI (6.90 BAR)  
 Polysulfone housing: 200 PSI (13.79 BAR)

### Readout accuracy, full scale: ±5%

## FLOW & PRESSURE DROP

These units impose a pressure drop that increases over rated flow range from 1.9 to 2.5 PSI (2.2 average).

## INSTALLATION

Flow monitors mount in-line and are typically supported by rigid pipe. For additional support when using tubing or flexible hose, order special options **W** (wall) or **F** (foot) mounting brackets.

## SPECIAL OPTIONS

**Identification tag:** (option **ST**) customer-supplied information is stamped on a stainless steel tag that is attached to the nameplate.

**Multi-pin connector:** Pin connectors (option **PC**) are available for rapid field installation. Meters are provided with the male half of either a micro or a mini pin connector. Check the chart below for the number of pins required for your control box selection and current type. Insert the number of pins in the code PC\_\_ for a mini connector or PC\_\_M for a micro connector. For example, a PC5 would be a 5 pin mini and PC5M would be a 5 pin Micro.

**Fault light:** (option **FL**) a red LED in nameplate indicates when a flow limit has been reached by internal switch contact. Helpful with multiple meters.

Add to end of symbol: **1** (1 light), **2** (2 lights), **A** (AC), **D** (DC), i.e. **FL2D**. Only available with service option "W" weatherproof enclosures or "X" corrosive service. Requires switch option and switch setpoint. For optional LED colors consult factory.

**Tempered-glass window:** (option **TG**) replaces the standard window. A tempered-glass window is employed where airborne solvents or high-ambient temperatures are common.

**Clearance vane:** (option **Z86**) the swing vane is modified to provide extra clearance for liquids that contain particulate. Available for maximum flow range of 5 TO 9 GPM. This reduces the turndown. The minimum flow is 1.5 GPM, which is standard for maximum flows 10 to 20 GPM.

Number of pins required for various combinations of current type, box type and switch option.

	AC switch options			1, 1B, 61, 71		3		53
	DC switch options	0	1, 1B, 61, 71	3	2, 2B, 54, 62, 72		53	
<b>Box</b>	A		3	4	6	5	3	4
	M		3	4		5		
	R		3	4	6	5	3	4
	RT	3						
	TT	3	3	4			3	4
	TTL	3	3	4			3	4
	GTL*	5						
	GTLZ*	3						
	GP*	3						

\*This box allows micro pin connectors only. Eg. PC3M or PC5M.

**DIMENSIONS (approximate) in inches**

**STANDARD OFFERING: Control Box "A"**

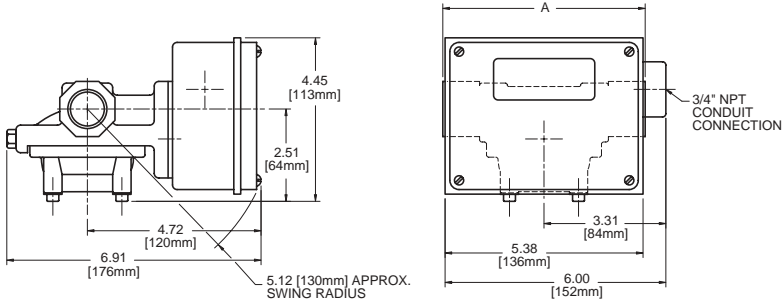

**STANDARD OFFERING: Control Box "X"**

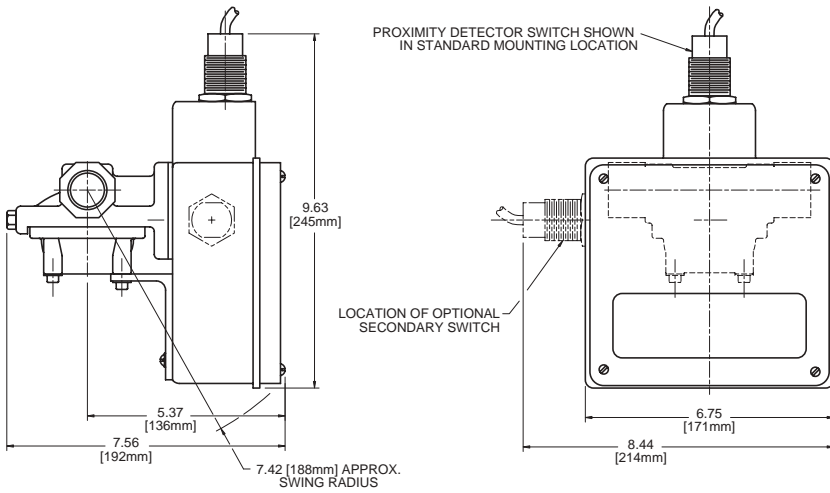

**STANDARD OFFERING: Control Box "G"**

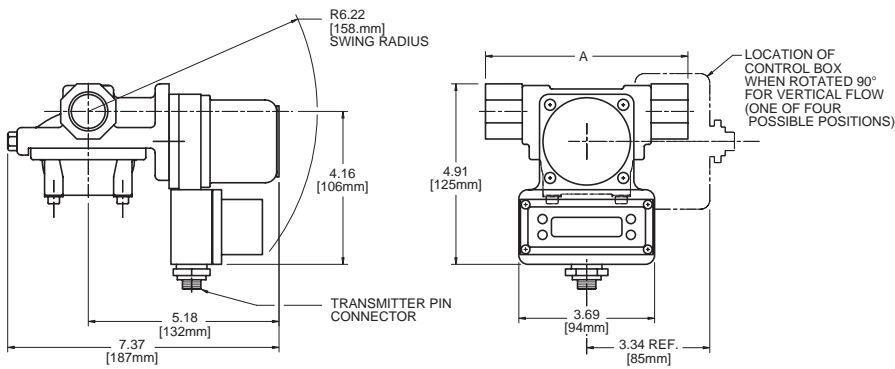

### SPECIAL OFFERING: Control Box "R"

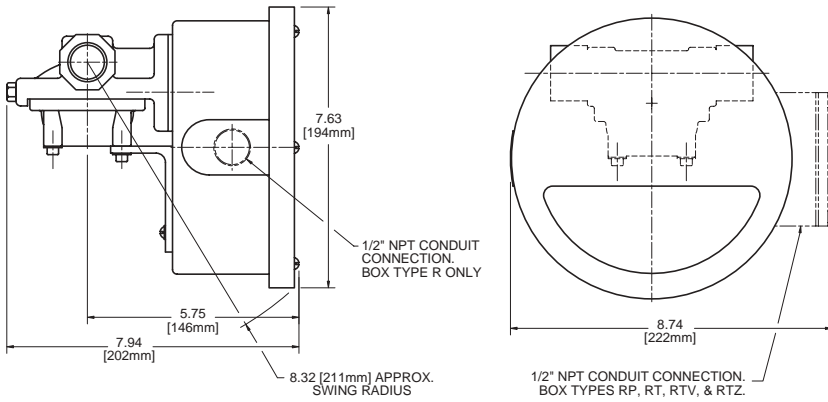

### SPECIAL OFFERING: Control Box "T"

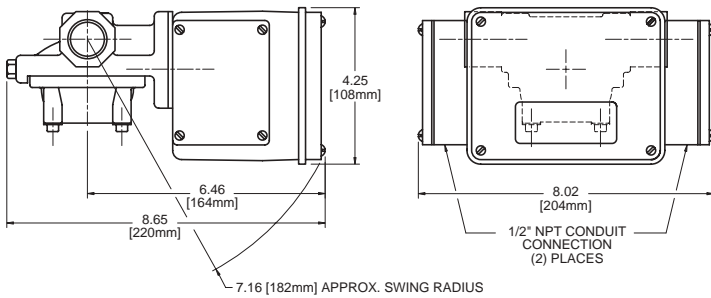

### SPECIAL OFFERING: Control Box "M"

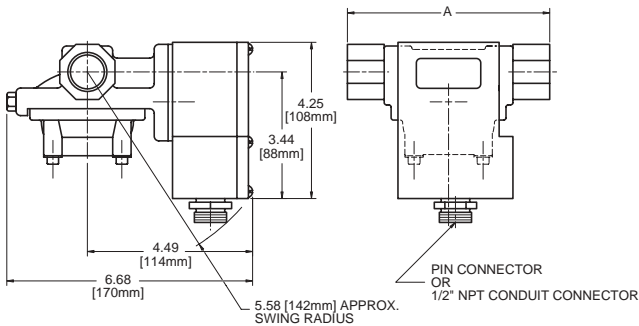

OVERALL PORT-TO-PORT DIMENSIONS FOR ALL SX METERS WITH ADAPTER FITTINGS. ALL DRAWINGS ARE SHOWN WITH FEMALE PLASTIC FITTINGS.

FITTING SIZE NPTF	A (INCHES)
1/4, MALE	6.00
1/2, MALE	6.25
3/4 OR 1, MALE	6.50
ALL FEMALE PLASTIC	5.50
ALL FEMALE S.S.	5.88

### MOUNTING BRACKETS (9/32-inch mounting holes)

