



MAX FLOW SIZES FROM  
0.5 TO 20 GPM (2 TO 75 LPM)

MAX LIQUID PRESSURE 300 PSI (20.69 BAR) **SN SERIES**  
 MAX LIQUID PRESSURE 500 PSI (34.48 BAR) **SM SERIES**  
 MAX LIQUID PRESSURE 2000 PSI (137.93 BAR) **SH SERIES**

# UNIVERSAL® Flow Meters

## A Small Vane Style For Liquids

 CSA Certified NRTL/C

 CE Marked (as noted)

**NIST** Traceable Calibration  
Certificate Available



*SN Series shown with  
"A" style control box*

### DESCRIPTION

These variable-area flow meters have a spring-loaded vane that swings open to accommodate more flow. Mounting is in-line and in any position. Straight pipe runs before or after the meter are not required. The all-mechanical sensing system responds quickly and directly drives the pointer and remote signaling devices. They handle shocks or flow surges beyond their rated capacities.

### CALIBRATION

All flow meters are individually calibrated for fluids with the viscosity you specify (up to 3000 SSU/650 centipoise). We also compensate for your fluid's specific gravity. For NIST Traceability please consult factory.

### CONSTRUCTION MATERIALS

The meter body, internal moving parts, and seals are offered in a variety of materials to suit a wide range of applications: water,

synthetic, and petroleum based oils, paint, some corrosives, solvents, and air and gases. Meter bodies are available in aluminum, anodized aluminum, brass, cast-iron, or nickel-plated cast-iron, naval bronze, carbon steel, or nickel-plated carbon steel, and 316 stainless steel. Aluminum, brass, and naval bronze are also available with optional nylon orifice cover. We offer internal moving parts in the following materials: 300 series stainless steel, 316 stainless steel, titanium, monel, and tantalum. Choices of materials for seals are: Buna N, EPR, Viton, and Kalrez™, and Teflon™ (Kalrez™ can be combined with the others). Please consult the factory for compatibility of materials with your application.

### LINE CONNECTION

Ports can be threaded or flanged. Threaded ports can be NPT (1/4 to 3/4") or SAE straight thread (1/4 to 5/8"). Metric threads such as BSPP, BSPT and JIS are also available. (ANSI Flanges (1/4 to 1") are standard with DIN Flanges also available.)

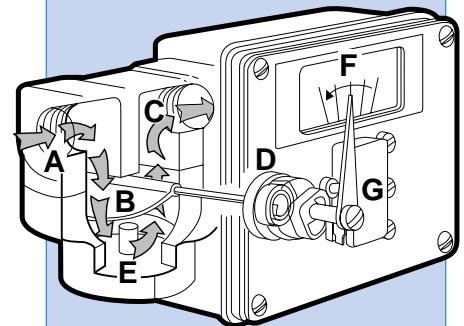

Fluid enters at A, passes around the semi-circular vane B. exits at outlet C. The vane resists the flow because of the spring D. The further the vane is pushed the larger the passageway E becomes. This minimizes the pressure drop. The vane shaft turns to operate the pointer F and remote signal devices such as the switch G.

**HOW TO ORDER** Select appropriate symbols and build a model code number, as in example shown:

**EXAMPLE: SN - A S B 7 GM V - 6 -**

SERIES	
Normal pressure (300 PSI)	= <b>SN</b>
Medium pressure (500 PSI)	= <b>SM</b>
High pressure (1500 PSI)	= <b>SH</b>

HOUSING MATERIAL (Series SN & SM)	
Aluminum	= <b>D</b>
Aluminum, nylon bowl	= <b>A*</b>
Aluminum (hard coated)	= <b>E</b>
Brass	= <b>F</b>
Brass, nylon bowl	= <b>B*</b>
Cast iron	= <b>C</b>
Cast iron, nickel plated	= <b>N</b>
Carbon steel	= <b>M</b>
Carbon steel, nickel plated	= <b>J</b>
Naval bronze	= <b>U</b>
Naval bronze, nylon bowl	= <b>W*</b>
Stainless steel (316)	= <b>I</b>

\*Available only on Series SN

HOUSING MATERIAL (Series SH)	
Cast iron	= <b>C</b>
Cast iron, nickel plated	= <b>N</b>
Carbon steel	= <b>M</b>
Carbon steel, nickel plated	= <b>J</b>
Stainless steel (316 carbon steel bolts standard, see Special Options)	= <b>I</b>

INTERNAL MOVING PARTS	
Stainless steel (300 & 416 series)	= <b>S</b>
Stainless steel (316)	= <b>I</b>
Titanium (N/A in SH)	= <b>T</b>
Monel (N/A in SH)	= <b>L</b>
Tantalum (N/A in SH)	= <b>R</b>

SEAL MATERIAL	
Buna N	= <b>B</b>
EPR	= <b>E</b>
Viton	= <b>F</b>
Kalrez	= <b>J</b>
Kalrez (dynamic) and Teflon (static) (all metal units only)	= <b>T</b>
Kalrez (dynamic) & Buna N (static)	= <b>A</b>
Kalrez (dynamic) and EPR (static)	= <b>H</b>
Kalrez (dynamic) and Viton (static)	= <b>K</b>

THREADED ATTACHMENT				
Pipe Size In Inches	NPT	SAE	BSPP	BSPT
1/4	2	4T	4BP	4BT
3/8	3	6T	6BP	6BT
1/2	4	8T	8BP	8BT
5/8		10T	10BP	10BT
3/4	6	12T	12BP	12BT

FLANGED Ex: 2 FW CS 150 RF				
Pipe Size	Attachment	Material	Pressure Rating	Style
2= 1/4 inch	FW= Welded	CS= Carbon Steel	150= 150PSI	RF= Ansi raised face
3= 3/8 inch	FT= Threaded	S= 316 Stainless	300= 300 PSI	D= Din
4= 1/2 inch			600= 600 PSI	
6= 3/4 inch				raised face
8= 1 inch				

VALVE (FLOW CONTROL) Series SN only	
No Symbol	= No Value
V	= Valve (brass) SN bodies only on models up to 7 GPM (25 LPM)
Not available on carbon steel or stainless steel housings	

SCALE CALIBRATIONS	
GH	= Calibrated in gallons per hour
GM	= Calibrated in gallons per minute
LH	= Calibrated in liters per hour
LM	= Calibrated in liters per minute
IGM	= Calibrated in imperial gallons per minute
CMH	= Cubic meters per hour
GLM	= Dual scales (GPM and LPM) (consult factory)
DGM	= Dual viscosity on GPM scale (consult factory)
DLM	= Dual viscosity on LPM scale (consult factory)
For specific calibrated increments and other scales consult factory.	

MAX FLOW RATING LIQUIDS				
These may be expressed in various engineering units as shown. Here we are selecting the maximum flow that the meter will see. The minimum reading is about 1/5th of the maximum. There are generally 5 to 7 major increments displayed on the analog scales (traditional mechanical pointer and inscribed scale) with that number roughly doubled for the high resolution "R" box which allows more accurate reading. Ultimate resolution is provided by the LCD digital display, standard with some transmitter selections. The following are the most commonly selected options for maximum flow rates for each engineering unit. More are available if you consult with the factory.				
	Viscosity minimum (SSU)			
	500	250	100	None
GPH:	30	60	90, 120	180, 240, 300, 200, 300, 400, 500, 600, 700, 800, 900, 1000, 1200
GPM:	.5	1	1.5, 2	3, 4, 5, 6, 7, 8, 9, 10, 15 & 20
LPM:	2	4	6, 8	10, 15, 20, 25, 30, 35, 40, 45, 50, 60, 75
LPH:	100	200	350, 500	600, 700, 800, 900, 1000, 1500, 2000, 2500, 3000, 3500, 4000
CMH:	.1	.25	.35, .5	.75, 1, 1.25, 1.5, 2, 2.5, 3, 3.5, 4, 4.5

*Consult factory for compatibility of construction materials with the fluid involved.*

**32V1.0 - A1 N R - ST - 2D**

**FLOW DIRECTION**

- R = Left to right
- L = Right to left
- U = Up
- D = Down

**SERVICE**

- N = Oil and dust tight (Type 12)
- W = Weatherproof (Type 4)
- X = Weatherproof, corrosion proof (Type 4X)

**SWITCH SETTING**

No symbol = Lowest possible  
 Or, give setting(s) in GPM or LPM. Also a symbol to indicate that accuracy is desired during increasing flow (U) or decreasing flow (D). (2D) would mean that switch should actuate when flow rate decreases to 2 GPM.)  
 Settings are field adjustable.

**SPECIAL OPTIONS**

**Standard**

- HT = High-temp- 400°F for A & R Box, 300°F for transmitter options all boxes (RT, T & G)
- ST = Stainless steel ID tag for customer supplied information
- PC = Pin connector (See explanation for special options.)
- FL = Fault light (See explanation for special options.)
- C = CSA enclosure / PVC window
- TG = Tempered glass window
- Z67SH = 316 stainless steel bolts on SH-I option. Pressure rating 1500 PSI Max.
- Z86 = Clearance vane for ≥ 5 GPM

**STANDARD CONTROL BOX & READOUT (switches)**

**A Box**

**Simple indication with or without switches**

- AØ = Scale & pointer only
- A1 = One SPDT (3wire) , CE
- A1B = One high vibration SPDT (3 wire), CE
- A2 = Two SPDT (3 wire), CE
- A2B = Two SPDT (3wire) , CE
- A3 = One SPDT (4 wire)
- A4 = Two SPDT (4 wire)
- A61 = One SPDT (3 wire) high temperature
- A62 = Two SPDT (3 wire) high temperature
- A71 = One SPDT (3wire) gold contact
- A72 = Two SPDT (3wire) gold contact
- A53 = One SPDT (3 wire) hermetically sealed
- A54 = Two SPDT (3 wire) hermetically sealed
- A11 = Pneumatic

**X Box**

**Hazardous location indication and switches**

- X7 = One SPDT hazardous location
- X7C = One SPDT, CE
- X17 = One DPDT hazardous location
- X17C = One DPDT, CE
- X3Ø = One SPST hazardous location proximity
- X31 = Two SPST hazardous location proximity

**G Box**

**Transmitter with digital display and 2 open collectors (standard), or remote display (optional)**

- GTLØ = internal 4-20 mA transmitter with two open collector alarms
- GTLZØ = intrinsically safe 4-20 mA transmitter (no alarms)
- GPØ = G Box with remote transmitter. This requires a remote display and transmitter to be ordered as a separate line item. Model UT-PM-DTLCD.

Note: G Box requires "W" service selection (weatherproof). G Box has a terminal strip but can be used with pin connectors ordered as Special Options as described above. Select PC5M for GTL and PC3M for GTLZ or GP.

**SPECIAL OFFERINGS**

**R Box**

**High resolution pointer and scale for more accurate reading, optional switches**

- RØ = Scale & pointer only
- R1 = One SPDT (3wire), CE
- R2 = Two SPDT (3 wire), CE
- R3 = One SPDT (4 wire)
- R4 = Two SPDT (4 wire)
- R53 = One SPDT (3 wire) hermetically sealed
- R54 = Two SPDT (3 wire) hermetically sealed
- R61 = One SPDT (3 wire) high temperature
- R62 = Two SPDT (3 wire) high temperature
- R71 = One SPDT (3wire) gold contact
- R72 = Two SPDT (3wire) gold contact

**RT Box**

**High resolution pointer and scale for more accurate reading, 4-20 mA Transmitter, optional high amp mechanical switch**

- RTØ = Scale & pointer only
- RT1 = One SPDT (3wire) , CE
- RT3 = One SPDT (4 wire)
- RT53 = One SPDT (3 wire) hermetically sealed
- RT61 = One SPDT (3 wire) high temperature
- RT71 = One SPDT (3wire) gold contact

**TT Box**

**4-20 mA Transmitter with pointer & scale, optional high amp mechanical switch, separate junction boxes for switch & transmitter**

- TTØ = Scale & pointer only
- TT1 = One SPDT (3wire) , CE
- TT3 = One SPDT (4 wire)
- TT53 = One SPDT (3 wire) hermetically sealed
- TT61 = One SPDT (3 wire) high temperature
- TT71 = One SPDT (3wire) gold contact

**TTL Box**

**4-20 mA Transmitter with digital display, optional high amp mechanical switch, separate junction boxes for switch & transmitter**

- TTLØ = Scale & pointer only
- TTL1 = One SPDT (3wire) , CE
- TTL3 = One SPDT (4 wire)
- TTL53 = One SPDT (3 wire) hermetically sealed
- TTL61 = One SPDT (3 wire) high temperature
- TTL71 = One SPDT (3wire) gold contact

**FLUID CHARACTERISTICS**

Viscosity number followed by a 'V' (for SSU), 'C' (for centipoise), or 'CS' (for centistokes) followed by the specific gravity. (32V1.0 would mean water.) For dual viscosity give two numbers separated by a slash (example: 320/500V1.0)

## ENGINEERING DATA

**Maximum fluid temperature:** 200°F (95°C)

**Optional max. fluid temperatures:**  
300 & 400°F (150 & 205°C) (option HT)

**Maximum ambient temp:** 150°F (65°C)  
CSA listed only to 105°F (40°C)

**Series SN max. operating pressure:**  
(3:1 safety factor): 300 PSI (20.69 BAR)

**Series SM max. operating pressure:**  
(2:1 safety factor): 500 PSI (34.48 BAR)

**Series SH max. operating pressure:**  
(3:1 safety factor) 2000 PSI (137.93 BAR)  
Stainless Steel with special option Z67SH,  
1500 PSI (103.42 BAR)

**Readout accuracy, full scale:** ±5%

## FLOW & PRESSURE DROP

Maximum flow ranges to 8 GPM/32 LPM = pressure drop from 1.9 to 2.5 PSID (2.2 PSID average).

Maximum flow ranges to 9 to 12 GPM/45 LPM = pressure drop from 1.9 to 4 PSID (2.95 PSID average).

Maximum flow ranges to 15 GPM/56 LPM = pressure drop from 1.9 to 5 PSID (3.5 PSID average).

Maximum flow ranges to 16 GPM/60 LPM = pressure drop from 1.9 to 5.5 PSID (3.7 PSID average).

Maximum flow ranges to 20 GPM/75 LPM = pressure drop from 1.9 to 6 PSID (4.0 PSID average).

## INSTALLATION

Flow monitors mount in-line and are typically supported by rigid pipe. For additional support when using tubing or flexible hose, order special options **W** (wall) or **F** (foot) mounting brackets. (Foot Mounting Bracket not available on SM and SH series).

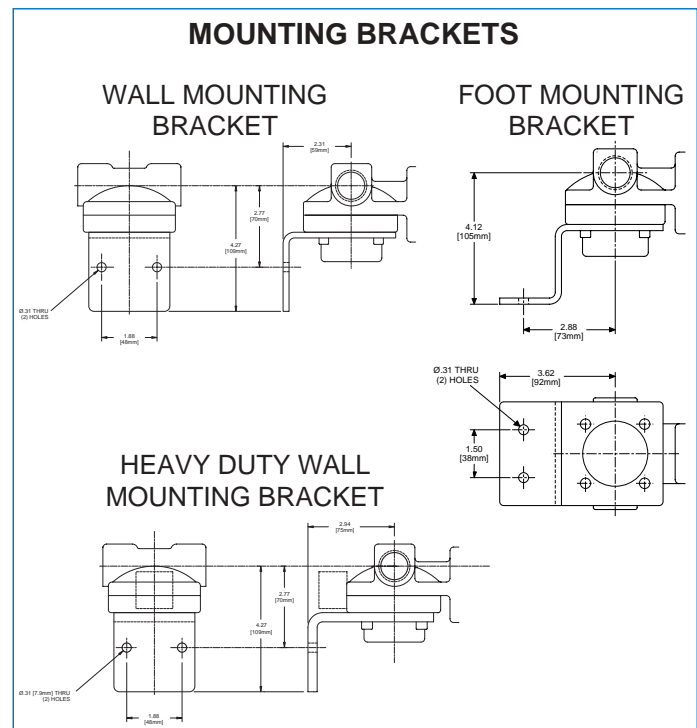

## SPECIAL OPTIONS

**High temperature:** (option HT) requires all-metal construction of housing/orifice cover with seals of Viton, EPR, Kalrez or Teflon (compatible with fluid). A thermal barrier (heat-resistant cloth) is added between the housing and the control box, which must be used with service option "W" (weatherproof) or "X" (corrosion resistant). A metal scale is provided.

**Identification tag:** (option ST) customer-supplied information is stamped on a stainless steel tag that is attached to the nameplate.

**Multi-pin connector:** (option PC) the male half of a mini or micro pin connector with enough pins to carry all signals, make all switches and to ground all AC switches. PC3 is a mini with 3 pins, PC3M is a micro pin. Up to 6 pins available.

**Fault light:** (option FL) a red LED in nameplate indicates when a flow limit has been reached by internal switch contact. Helpful with multiple meters. Add to end of symbol: **1** (1 light), **2** (2 lights), **A** (AC), **D** (DC), i.e. **FL2D**. Only available with service option "W" weatherproof enclosures or "X" corrosive service. Requires switch option and switch setpoint. For optional LED colors consult factory.

**Tempered-glass window:** (option TG) replaces the standard window. A tempered-glass window is employed where airborne solvents or high-ambient temperatures are common.

**Clearance vane:** (option Z86) the swing vane is modified to provide extra clearance for liquids that contain particulate. Available for maximum flow range of 5 TO 9 GPM. This reduces the turndown. The minimum flow is 1.5 GPM. Z86 is standard for maximum flows 10 to 20 GPM.

**Number of pins required for various combinations of current type, box type and switch option.**

	AC switch options			1, 1B, 61, 71		3		53
	DC switch options	0	1, 1B, 61, 71	3	2, 2B, 54, 62, 72	53		
Box	A		3	4	6	5	3	4
	M		3	4		5		
	R		3	4	6	5	3	4
	RT	3						
	TT	3	3	4			3	4
	TTL	3	3	4			3	4
	GTL*	5						
	GTLZ*	3						
	GP*	3						

\*This box allows micro pin connectors only. Eg. PC3M or PC5M.

## DIMENSIONS (approximate) in inches

### STANDARD OFFERING: Control Box "A"

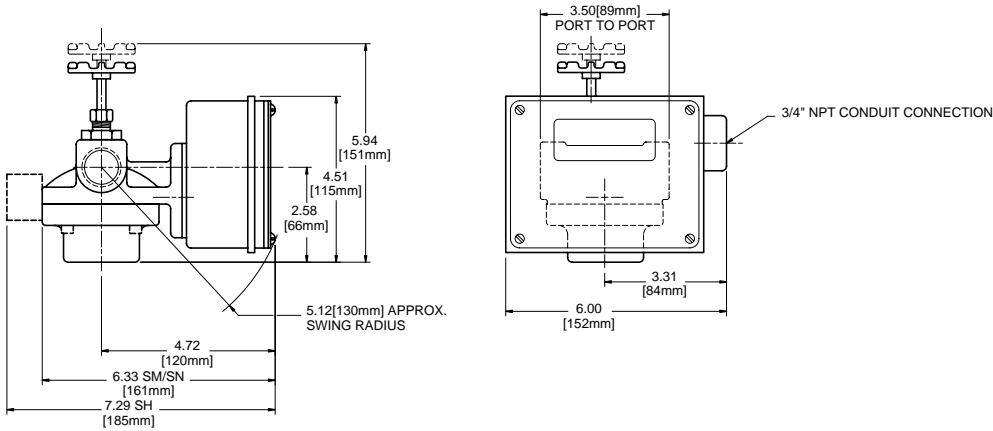

### STANDARD OFFERING: Control Box "X"

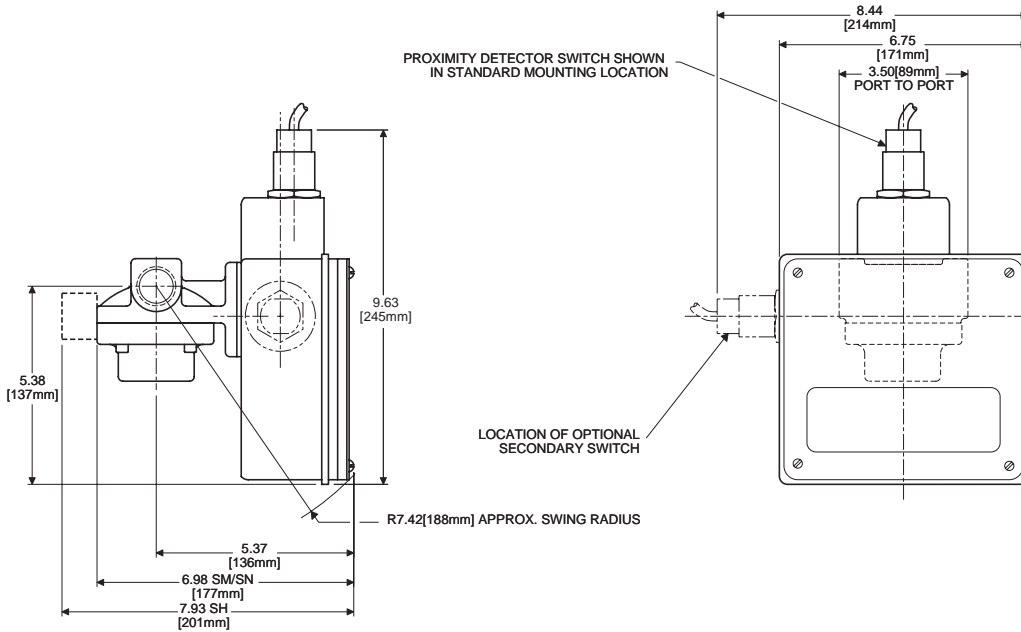

### STANDARD OFFERING: Control Box "G"

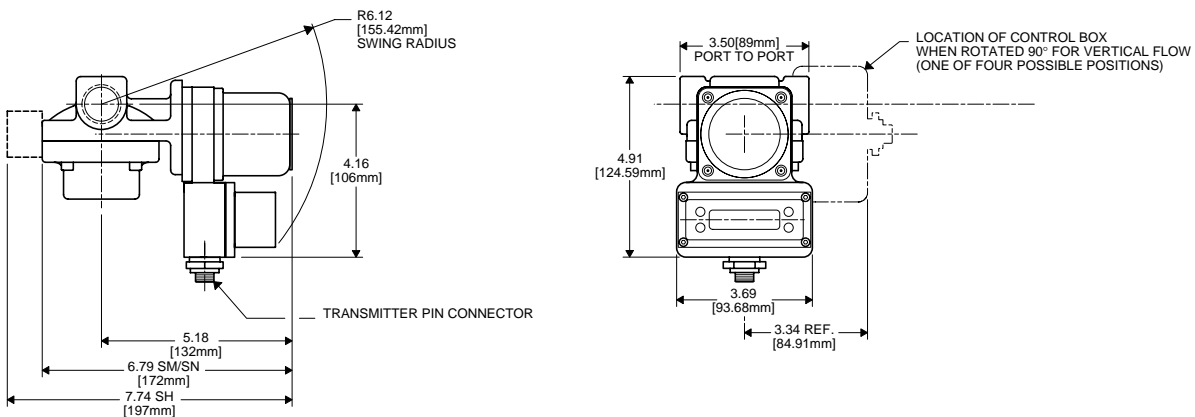

**DIMENSIONS (approximate) in inches**

**SPECIAL OFFERING: Control Box "R"**

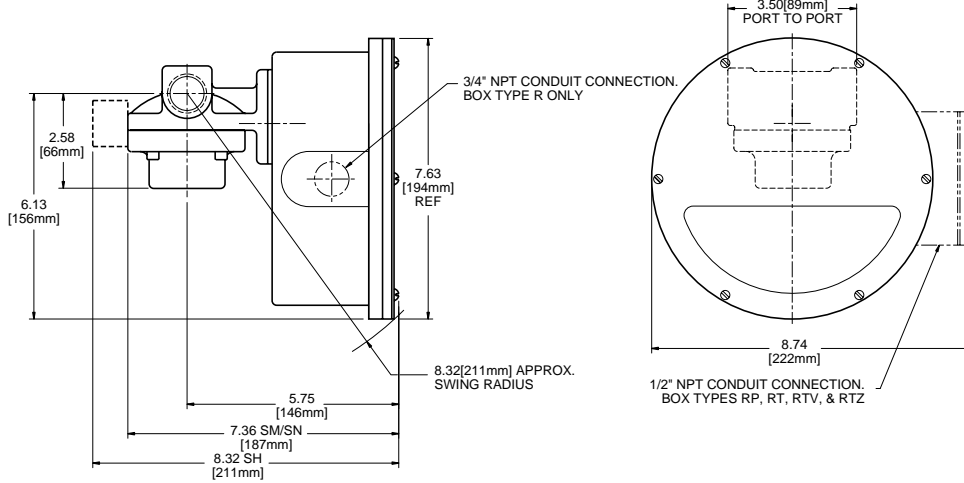

**SPECIAL OFFERING: Control Box "T"**

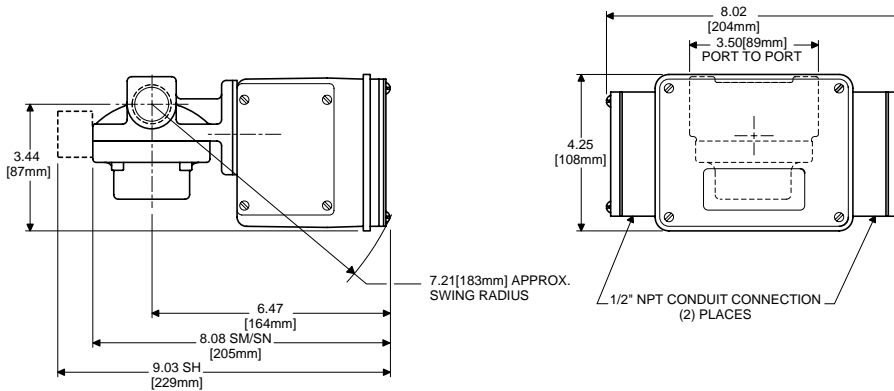

**With 150 lb R.F. flanges**  
(for other flanges consult factory)

Port Size (inches)	A (inches)
1/2	3.50
3/4	3.87
1	4.25

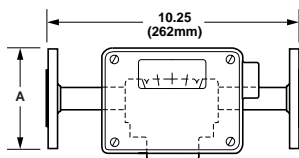

"Flow up" or "flow down" dimensions are the same.  
Scale numbers are turned 90° to read correctly.



**Universal Flow Monitors, Inc.**

1755 E. Nine Mile Road ▪ P.O. Box 249  
Hazel Park, MI 48030  
Tel: 248-542-9635 ▪ Fax: 248-398-4274  
www.flowmeters.com  
E-mail: ufm@flowmeters.com