

UNIVERSAL[®] Flow Meters

A Large Vane Style For Liquids

 CSA Certified NRTL/C

 CE Marked (as noted)

NIST Traceable Calibration
Certificate Available



LN Series, with standard scale and pointer (control box R).

DESCRIPTION

These variable-area flow meters have a spring-loaded swinging vane. Mounting is in-line and in any position. Straight pipe runs, before or after the meter, are not required. The all-mechanical sensing system directly drives the pointer and remote signaling devices. They handle shocks or flow surges beyond their rated capacities.

This swinging vane can be manually operated with a wrench (factory supplied) to verify or adjust switch points or to free the vane should it become lodged by debris in the fluid.

CALIBRATION

All flow meters are individually calibrated for fluids with the viscosity you specify (up to 3000 SSU/650 centipoise). We also compensate for your fluid's specific gravity. For NIST Traceability please consult factory.

CONSTRUCTION MATERIALS

The meter body, internal moving parts, and seals are offered in a variety of materials to suit a wide range of applications: water, synthetic and petroleum based oils, paint, some corrosives, solvents, air and gases. Meter bodies are available in aluminum, brass, cast iron or nickel-plated cast iron, carbon steel or nickel-plated carbon steel, naval bronze, or 316 stainless steel. We offer internal moving parts in the following materials: 300 series stainless steel, 316 stainless steel, monel, and titanium. Choices of materials for seals: Buna N, EPR, Viton, and Kalrez (Kalrez can be combined with others). Please consult the factory for compatibility of materials with your application.

LINE CONNECTION

Ports can be from 1-1/2 to 4 inches. All connections have 300# SAE mating flanges, either threaded NPT or socket-weld type. Metric threads such as BSPP, BSPT, JIS, etc. are available. Other flanges available; consult factory.

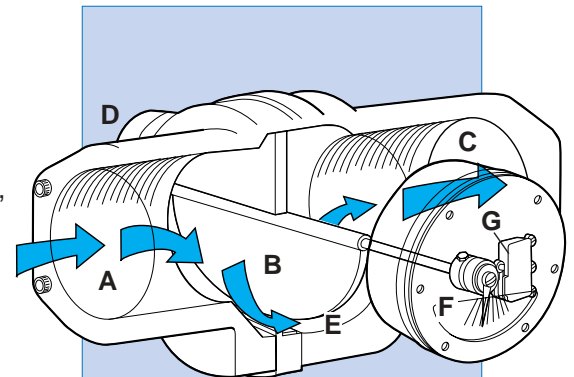

Fluid enters at **A**, passes around the semi-circular vane **B**, exits at outlet **C**. The vane resists the flow because of the spring **D**. The further the vane is pushed the larger the passageway **E** becomes. This minimizes pressure drop. The vane shaft turns to operate the pointer **F** and remote signal devices such as the switch **G**.

HOW TO ORDER Select appropriate symbols and build a model code number, as in example shown:

EXAMPLE: LN - F S F 200 GM - 20 - 32V1.0 -

SERIES

Large vane style
 Normal pressure = LN
 High pressure = LE

HOUSING MATERIAL (Series LN)

Aluminum = D
 Aluminum (hard coated) = E
 Brass = F
 Cast iron = C
 Cast iron, nickel plated = N
 Carbon steel = M
 Naval bronze = U
 Stainless steel (316) = I
 Alum./Brass Center Section = Q

HOUSING MATERIAL (Series LE)

Carbon steel = M
 Carbon steel, nickel plated = J
 Stainless steel (316) = I

INTERNAL MOVING PARTS

Stainless steel (300 series) = S
 Stainless steel (316) = I
 Monel = L
 Titanium = T

SEAL MATERIAL

Buna N = B
 EPR (not avail. on petroleum base fluid) = E
 Viton = F
 Kalrez (dynamic) and Teflon (static) = T
 Kalrez (dynamic) and Buna N (static) = A
 Kalrez (dynamic) and EPR (static) = H
 Kalrez (dynamic) and Viton (static) = K

MAX FLOW RATING

Gallons Per Minute		GPM	
Calibration Increments		Reading	
Round Boxes	Other Boxes	Min - Max	
5	10	8 - 80	
5	10	10 - 100	
5	20	10 - 150	
10	20	20 - 200	
10	25	30 - 300	
20	25	50 - 400*	
20	25	50 - 500*	

Liters Per Minute		LPM	
Calibration Increments		Reading	
Round Boxes	Other Boxes	Min - Max	
10	25	30 - 300	
20	25	40 - 400	
20	50	40 - 600	
25	100	80 - 800	
50	100	120 - 1200	
50	100	150 - 1500*	
100	100	180 - 1800*	

Cubic Meters Per Hour		CMH	
Calibration Increments		Reading	
Round Boxes	Other Boxes	Min - Max	
2	10	4 - 40	
2	10	5 - 50	
2	10	7 - 70	
5	20	10 - 90*	
5	20	10 - 120*	

Note: Custom scales are available in any units and increments on special order.
 *Requires special option dual spring (DS).

FLUID CHARACTERISTICS

Viscosity number, followed by a 'V' (for SSU), a 'C' (for centipoise), or a 'CS' (for centistokes), plus the fluid specific gravity. (32V 1.0 would mean water.) For dual viscosity give two numbers separated by a slash (example: 320/500V1.0).

PORT CONNECTION

Inches	MM	Threaded	Socket-Weld	ANSI	Max. Flow
		SAE-Style	SAE-Style	Style	
		Flanges	Flanges	Flanges	(GPM) (LPM)
		(NPT)	(Pipe)		
1-1/2	38.10	= 12	= 12W	= 12F	100 378
2	50.80	= 16	= 16W	= 16F	150 567
2-1/2	63.50	= 20	= 20W	= 20F	300 1134
3	76.20	= 24	= 24W	= 24F	400 1512
4	101.6	= 32	= 32W	= 32F	500 1890

Flanges are steel; stainless steel units have stainless steel flanges. ANSI flanges also available. (Refer to page 129)

SCALE CALIBRATIONS

Calibrated in gallons per minute = GM
 Calibrated in liters per minute = LM
 Dual scales (GPM and LPM)* = GLM
 Cubic meters per hour* = CMH

*For specific calibrated increments and other scales consult factory

Consult factory for compatibility of construction materials with the fluid involved.

R61 W R - HT 100D

FLOW DIRECTION

- R** = Left to right
- L** = Right to left
- U** = Up
- D** = Down

SERVICE

- W** = Weatherproof (Type 4)
- X** = Weatherproof, corrosion proof (Type 4X)

INITIAL SWITCH SETTING

No symbol = Lowest possible
 Or, give setting(s) in GPM, LPM, etc. Also a symbol to indicate that accuracy is desired during increasing flow (**U**) or decreasing flow (**D**). **100D** would mean that switch will actuate when flow rate decreases to 100 GPM.) Settings are field adjustable.

SPECIAL OPTIONS

- HT** = High-temp, 400°F for A & R Box (300°F for transmitter options GT, RT & TT Boxes)
 - ST** = Stainless steel ID tag
 - PC*** = Pin connector with 3-6 pins, mini and micro style available
 - FL*** = Fault light(s)
 - TG** = Tempered glass window
- Note:** These options are described more fully in "Options for Vane and Piston style flowmeters."

STANDARD CONTROL BOX & READOUT (switches)

R Box

High resolution pointer and scale for more accurate reading, optional switches

- R0 = Scale & pointer only
- R1 = One SPDT (3wire), CE
- R2 = Two SPDT (3 wire), CE
- R3 = One SPDT (4 wire)
- R4 = Two SPDT (4 wire)
- R53 = One SPDT (3 wire) hermetically sealed
- R54 = Two SPDT (3 wire) hermetically sealed
- R61** = One SPDT (3 wire) high temperature
- R62 = Two SPDT (3 wire) high temperature
- R71 = One SPDT (3wire) gold contact
- R72 = Two SPDT (3wire) gold contact

X Box

Hazardous location indication and switches

- X7 = One SPDT hazardous location
- X7C = One SPDT, CE
- X17 = One DPDT hazardous location
- X17C = One DPDT, CE
- X30 = One SPST hazardous location proximity
- X31 = Two SPST hazardous location proximity

G Box

Transmitter with digital display or remote display (standard), open collector alarms (optional)

- GTL0 = internal 4-20 mA transmitter with two open collector alarms
- GTLZ0 = intrinsically safe 4-20 mA transmitter (no alarms)
- GP0 = G Box with remote transmitter. This requires a remote display and transmitter to be ordered as a separate line item. Model UT-PM-DTLCD.

Note: G Box requires "W" service selection (weatherproof). G Box has a terminal strip but can be used with pin connectors ordered as Special Options as described above. Select PC5M for GTL and PC3M for GTLZ or GP.

SPECIAL OFFERINGS

RT Box

High resolution pointer and scale for more accurate reading, 4-20 mA Transmitter, optional high amp mechanical switch

- RT0 = Scale & pointer only
- RT1 = One SPDT (3wire), CE
- RT53 = One SPDT (3 wire) hermetically sealed
- RT61 = One SPDT (3 wire) high temperature
- RT71 = One SPDT (3wire) gold contact

TT Box

4-20 mA Transmitter with pointer & scale, optional high amp mechanical switch, separate junction boxes for switch & transmitter

- TT0 = Scale & pointer only
- TT1 = One SPDT (3wire), CE
- TT3 = One SPDT (4 wire)
- TT53 = One SPDT (3 wire) hermetically sealed
- TT61 = One SPDT (3 wire) high temperature
- TT71 = One SPDT (3wire) gold contact

TTL Box

4-20 mA Transmitter with digital display, optional high amp mechanical switch, separate junction boxes for switch & transmitter

- TTL0 = Scale & pointer only
- TTL1 = One SPDT (3wire), CE
- TTL3 = One SPDT (4 wire)
- TTL53 = One SPDT (3 wire) hermetically sealed
- TTL61 = One SPDT (3 wire) high temperature
- TTL71 = One SPDT (3wire) gold contact

DIMENSIONS, LN & LE SERIES (approximate) in inches

STANDARD OFFERING: Control Box "R"

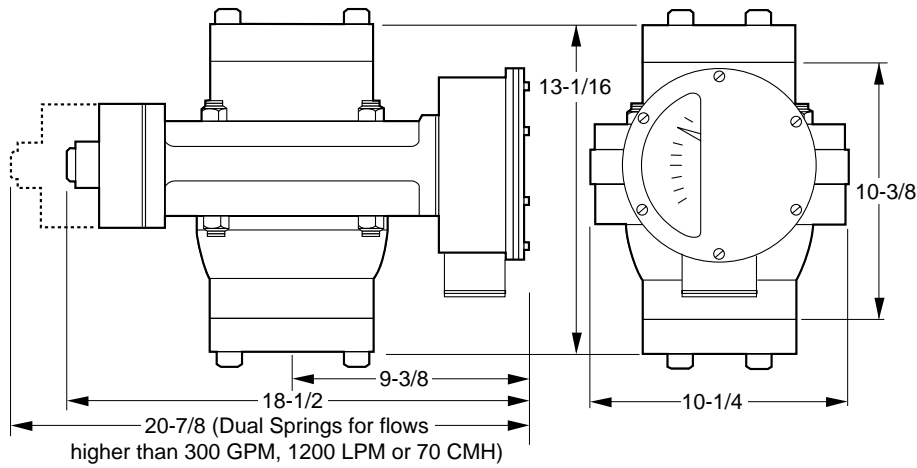

With 150 lb R.F. flanges
(for other flanges consult factory)

Port Size (inches)	A
1-1/2	5
2	6
2-1/2	7
3	7-1/2
4	9

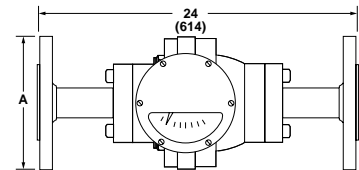

"Flow up" or "flow down" dimensions are the same. Scale numbers are turned 90° to be right reading. For additional information on flanged connection see page 129.

STANDARD OFFERING: Control Box "X"

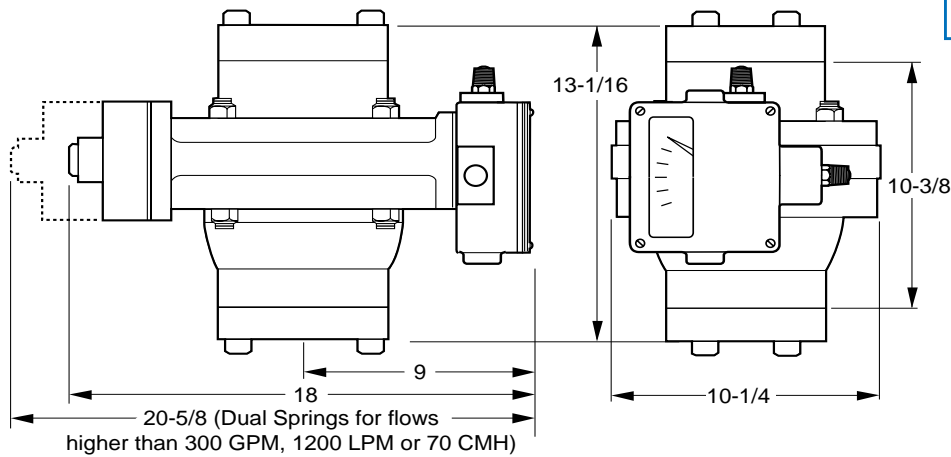

STANDARD OFFERING: Control Box "G"

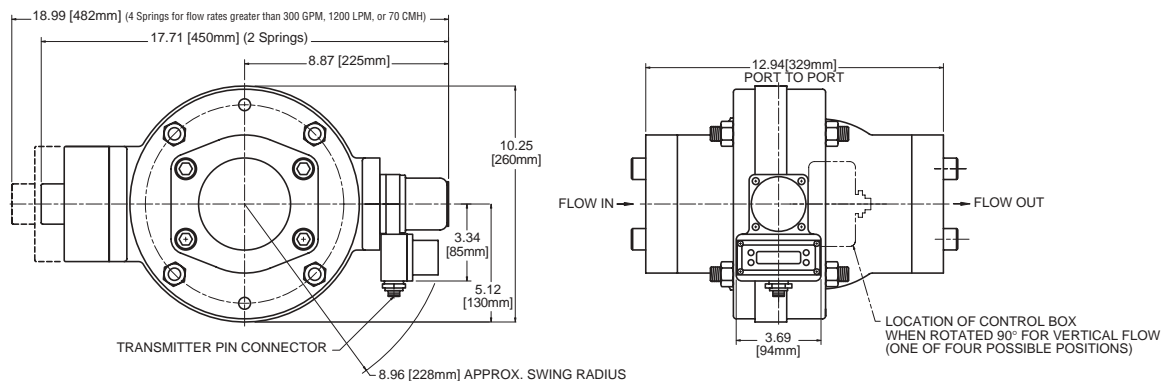

DIMENSIONS, LN & LE SERIES (approximate) in inches

SPECIAL OFFERING: Control Box "T"

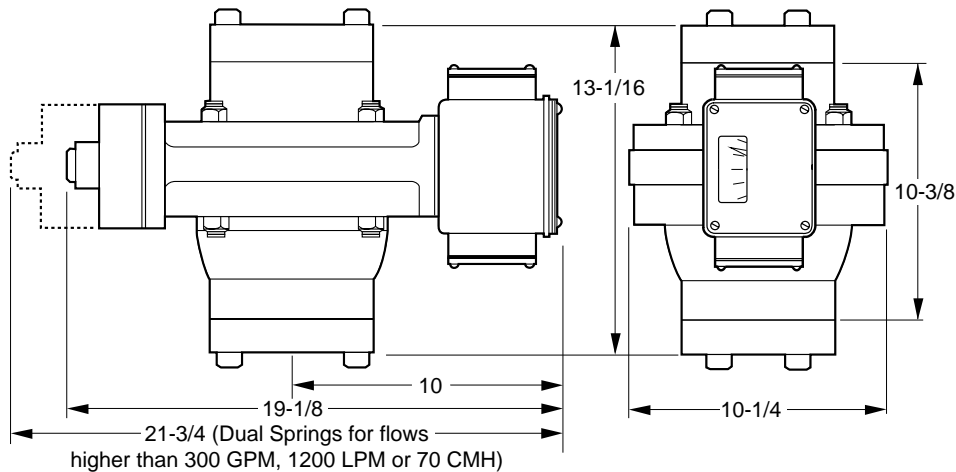

ENGINEERING DATA

Maximum fluid temperature:
200°F (95°C)

Optional max. fluid temperatures:
300 & 400°F (150 & 205°C)
(option HT)

Max. ambient temp: 150°F (65°C)
CSA listed only to 105°F (40°C)

SERIES LN
max. operating pressures
(3:1 safety factor):
300 PSI (20.69 BAR)

SERIES LE
max. operating pressures
(2:1 safety factor):
1000 PSI (68.97 BAR)

Readout accuracy, full scale: ±2%

FLOW & PRESSURE DROP

Meters with maximum flows to 300 GPM (1200 LPM) impose a pressure drop that increases with flow from 1.9 to 3.8 PSI (avg. 2.2). Flows greater than 400 GPM are made possible by having a dual spring modification (which raises the pressure drop). The pressure drop at maximum flow is 5.5 PSI.

SPECIAL OPTIONS

High temperature: (option HT) requires seals of Viton, EPR, Kalrez or Teflon (compatible with fluid). A thermal barrier (heat-resistant cloth) is added between the housing and the control box, which must be used with service option "W" (weather-proof) or "X" (corrosion resistant). A metal scale is provided.

Identification tag: (option ST) customer-supplied information is stamped on a stainless steel tag that is attached to the nameplate.

Multi-pin connector: (option PC) the male half of a Brad-Harrison type multi-pin connector is pre-wired to switch(es), potentiometer or transmitter for quick and easy field installation. Maximum current for multi-pin connectors is 7 amps. Refer to available output types for additional ordering information, page 124.

Fault light: (option FL) a red LED in nameplate indicates when a flow limit has been reached by internal switch contact. Helpful with multiple meters. Add to end of symbol: **1** (1 light), **2** (2 lights), **A** (AC), **D** (DC), i.e. **FL2D**. Only available with service option "W" weatherproof enclosures or "X" corrosive service. Requires switch option and switch setpoint. For optional LED colors, consult factory.

CE marked switches: (option CE) SPDT 3-wire switch for general purpose use. Standard on switches 1, 1B, 2 and 2B, optional on 3, 4, 61, 62, 71 and 72.

Tempered-glass window: (option TG) replaces the standard window. A tempered-glass window is employed where airborne solvents or high-ambient temperatures are common.



Universal Flow Monitors, Inc.

1755 E. Nine Mile Road ▪ P.O. Box 249 ▪ Hazel Park, MI 48030
Tel: 248-542-9635 ▪ Fax: 248-398-4274
www.flowmeters.com ▪ E-mail: ufm@flowmeters.com