

# M80 - 3" PULSE & LCD DISPLAY METERS

The M80 is a large capacity meter in the M Series range. It has the ability to handle a wide range of fluid viscosities with exceptional levels of repeatability and durability.



**M80AAG-X**

## Product Benefits

- Compact size.
- Two independent pulse units.
- Flexibility of installation options (e.g. can be mounted horizontally or vertically; no flow conditioning required).
- Low pressure drop allows for economical pump selection or gravity flow applications.
- Meter construction enables fast and easy on-site servicing without removal from application.
- Meter design minimises the number of wearable and replaceable parts and extends product life.
- Meter accuracy is verified by a factory calibration check after which an individual metrology report is issued.
- Both LC Displays meets European CE directive for EMC.
- Standard/Deluxe Displays and Pulse Version have IP65/NEMA9 protection.
- Intrinsically safe LC Deluxe and Standard Displays. Certificate of conformity number PTB Nr. Ex-93.C.4033x & Kema Ex-00.E.1127x

MODEL	M80
METER TYPE	PULSE / STANDARD LC DISPLAY / DELUXE LC DISPLAY
METER BODY MATERIAL	ALUMINIUM
WETTED COMPONENTS:	
ROTOR MATERIAL	ALUMINIUM
SHAFTS	316 STAINLESS STEEL
O-RING	NBR (NITRILE)
FLOW RATE RANGES (litres per minute/US gallons per minute)	
ABOVE 5 CPS	20 to 733 / 5 to 194
BELOW 5 CPS	66 to 616 / 17 to 163
ACCURACY- WITHIN (OF READING)	+/- 0.5%
REPEATABILITY	0.03%
MAXIMUM VISCOSITY (OF STANDARD MODEL)	1000 Centipoise
MAXIMUM OPERATING PRESSURE	1200KPA/175PSI/12BAR
PULSER TYPE	HALL EFFECT OR REED SWITCH OR COMBINATION HE / RS
PULSES PER LITRE/US GALLONS	2.59 / 9.8
MAX. OPERATING TEMPERATURE	80°C / 176°F
RECOMMENDED MESH STRAINER SIZE	40 MESH



Standard LC Display



Deluxe LC Display

**Port Size** To order flowmeter you must replace 'X' with the relevant number. This number will determine the following specifications:

### Port Size:

- 1 = 3" BSP (F) Ports
- 2 = 3" NPT (F) Ports
- 3 = 3" ANSI 150lb Flange
- 4 = 3" ANSI 150lb Flange
- 5 = 80mm DIN 16 Flange
- 13 = 80mm JIS 10K Flange

### Calibrated and Display In:

- Litres
- US Gallons
- Litres
- US Gallons
- Litres
- Litres

### Electrical Conduit Connection:

- 20mm (F)
- 1/2" NPT (F)
- 20mm (F)
- 1/2" NPT (F)
- 20mm (F)
- 20mm (F)

PPS = Polyphenylene Sulfide Resins



# M80 - 3" PULSE & LCD DISPLAY METERS

## Options & Accessories

M80 - 3" METER	VITON O-RING	TEFLON O-RING	EPDM O-RING	HIGH TEMP ROTORS	HIGH VISCOSITY ROTORS	HALL EFFECT SENSOR	REED SWITCH	SOLVENT KIT	HASTALLOY C SHAFTS	PROTECTIVE BOOT DELUXE LCD	EXTENDED LIFE BATTERY DELUXE LCD	REMOTE MOUNTED LC DISPLAY	HEATING JACKET	4-20mA MODULE
M80AAX-X	O	O	O	X	X	O	S	X	X	A	A	A	X	A

S = Standard

O = Optional

X = Not Available

A = Accessory

## Dimensions

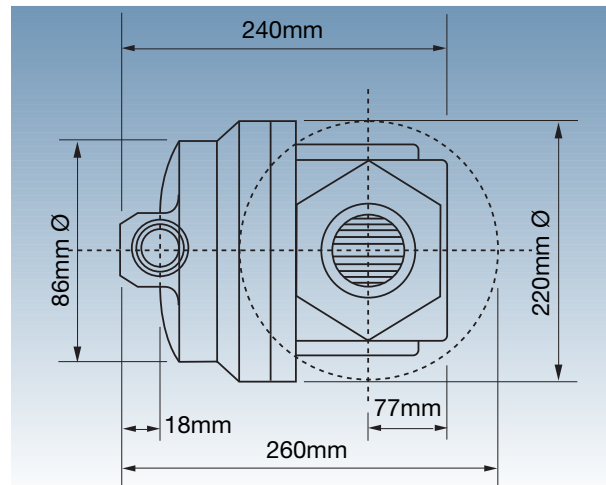
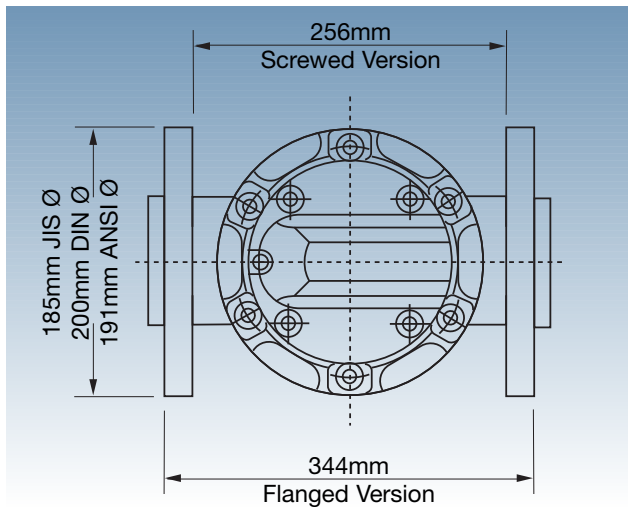

Pulse Version

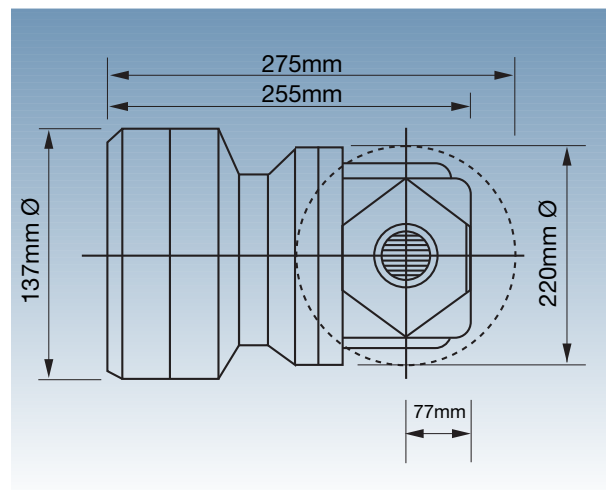
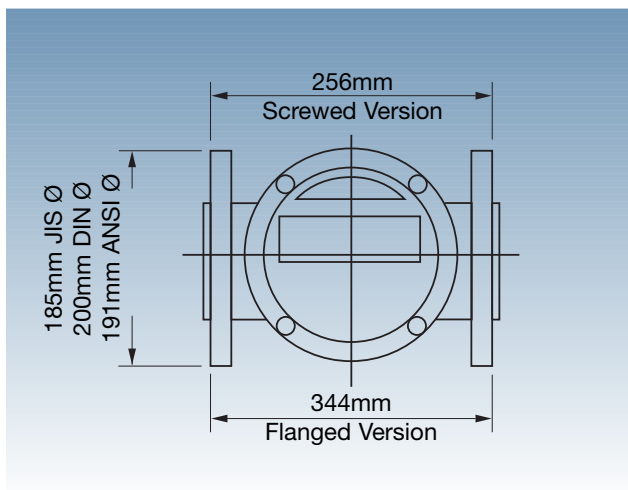

Standard/Deluxe Display

Macnaught Pty Ltd reserves the right to modify or alter product materials, dimensions, design and construction, when necessary, to improve the performance of our products. Please check with your local distributor or Macnaught to confirm current specifications of our products

TYPE M80 - 3" PULSE & LCD DISPLAY METERS