

# M50 - 2" METERS WITH MECHANICAL DISPLAY

The M50 is the medium to large capacity meter in the M Series range. It has the ability to handle a wide range of fluid viscosities with exceptional levels of repeatability and durability.



M50ARM-X

## Product Benefits

- Compact size.
- Easy to read and operate mechanical display.
- Flexibility of installation options (e.g. can be mounted horizontally or vertically; no flow conditioning required).
- Low pressure drop allows for economical pump selection or gravity flow applications.
- Meter construction enables fast and easy on-site servicing without removal from application.
- Meter accuracy is verified by a factory calibration check after which an individual metrology report is issued.
- Meter design minimises the number of wearable and replaceable parts and extends product life.
- An Option of 100 Pulses per unit of measure output is available for the Analogue version.

MODEL	M50
METER TYPE	METER WITH MECHANICAL DISPLAY
METER BODY MATERIAL	ALUMINIUM / 316 STAINLESS STEEL/ BRONZE
WETTED COMPONENTS: ROTOR MATERIAL SHAFTS O-RING	PPS / 316 STAINLESS STEEL 316 STAINLESS STEEL NBR (NITRILE)
FLOW RATE RANGES (litres per minute/US gallons per minute) ABOVE 5 CPS BELOW 5 CPS	15 to 350 / 4 to 93 30 to 300 / 8 to 79
ACCURACY- WITHIN (OF READING) REPEATABILITY	+/- 1% ANALOGUE REGISTER +/- 0.5% 0.03%
MAXIMUM VISCOSITY (OF STANDARD MODEL)	1000 Centipoise
MAXIMUM OPERATING PRESSURE	1800KPA/260PSI/18BAR
MAX. OPERATING TEMPERATURE	80°C / 176°F, High Temp Option 120°C / 240°F
RECOMMENDED MESH STRAINER SIZE	60 MESH



Mechanical Display



Analogue Mechanical Register

**Port Size** To order flowmeter you must replace 'X' with the relevant number. This number will determine the following specifications:

### Port Size:

- 1 = 2" BSP (F) Ports
- 2 = 2" NPT (F) Ports
- 3 = 2" ANSI 150lb Flange
- 4 = 2" ANSI 150lb Flange
- 5 = 50mm DIN 16 Flange
- 13=50mm JIS 10k flange

### Calibrated and Display In:

- Litres
- US Gallons
- Litres
- US Gallons
- Litres
- Litres

PPS = Polyphenylene Sulphide Resins



# M50 - 2" METERS WITH MECHANICAL DISPLAY

## Options & Accessories

M50 - 2" MECHANICAL DISPLAY	VITON O-RING	TEFLON O-RING	EPDM O-RING	HIGH TEMP ROTORS	HIGH VISCOSITY ROTORS	HALL EFFECT SENSOR	REED SWITCH	SOLVENT KIT	HASTALLOY C SHAFTS	ANALOGUE REGISTER	PULSER KIT P500	REMOTE MOUNTED LC DISPLAY	HEATING JACKET	4-20mA MODULE
M50ARM-X	O	O	O	O	O	X	X	O	X	O	A	X	A	X
M50SRM-X	O	O	O	O	O	X	X	S	X	O	A	X	A	X
M50SSM-X	O	O	O	S	O	X	X	S	X	O	A	X	A	X
M50ASM-X	O	O	O	S	O	X	X	S	X	O	A	X	A	X

S = Standard

O = Optional

X = Not Available

A = Accessory

## Dimensions

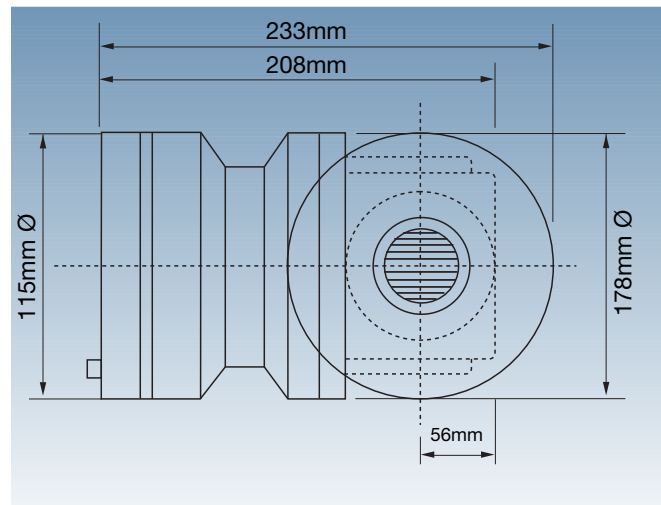
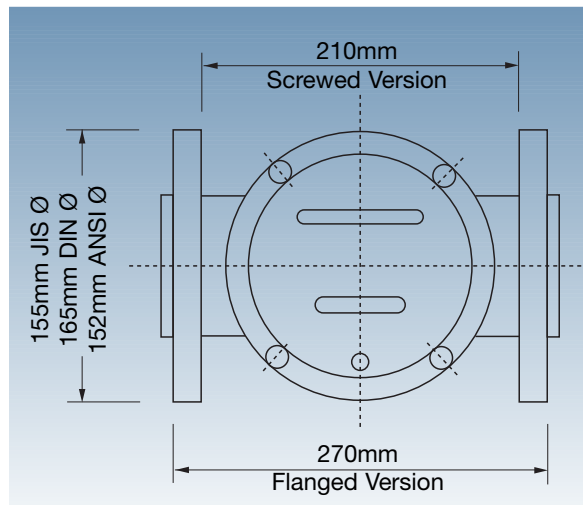

Mechanical Display

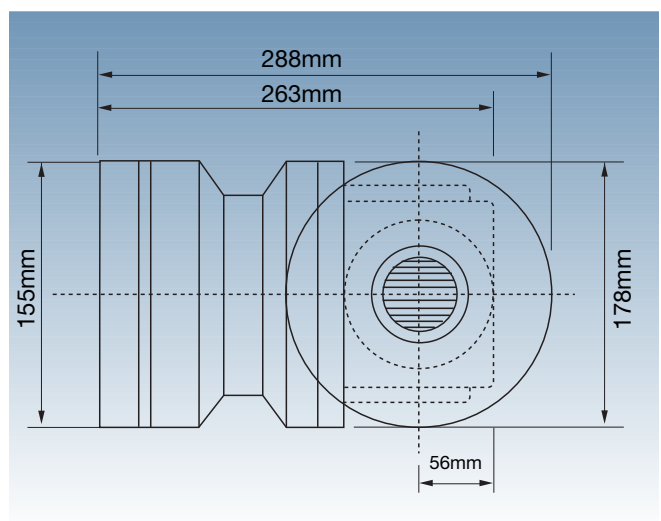
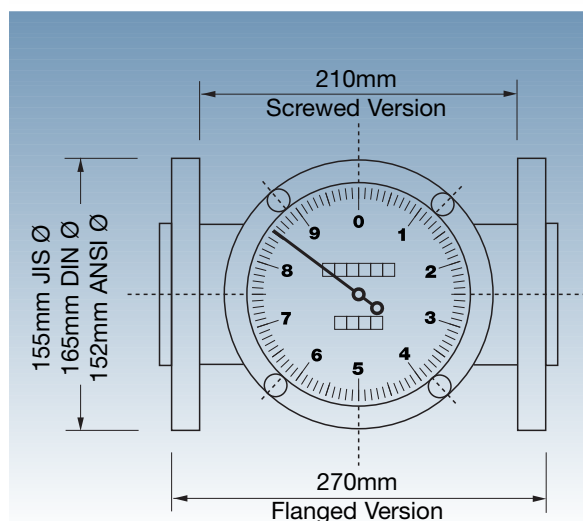

Analogue Mechanical Display

Macnaught Pty Ltd reserves the right to modify or alter product materials, dimensions, design and construction, when necessary, to improve the performance of our products. Please check with your local distributor or Macnaught to confirm current specifications of our products